

2015 **Audi Sport**

R8

RS

S

Audi
Truth in Engineering



We have the technology to convert racing fuel into champagne.

It's amazing what passion and a sense of purpose can do. In olden days, alchemists tried to turn base metals into gold, with little success. But Audi has a tried and true method to transform racing fuel into champagne: winning motorsports championships. For more than 80 years, that's a formula that has never failed us. We win because our engineers imbue our vehicles with precision and power, and with decades of innovations that help us outsmart the opposition as much as outdrive them. We design machines that make pulses race almost as fast as our racecars do. With Audi Sport® performance cars, we've built on this impressive heritage and released it on the American road. Our technology, the handling, the control, the performance—these are the elements we start with. Audi Sport. Here's a toast to some powerful alchemy.¹

RACING FUEL

100 PT. CHAMPAGNE, 1998

Audi Sport
Truth in Engineering



R8

Audi Sport is distilled into its purest form with the track-born Audi R8. The uncompromising progressive supercar, the R8 stands apart. Coiled at the pinnacle of performance, the R8 is ready at a moment's notice to forcefully express the style, craft and dynamic engineering behind Audi power.

RS

Imagine track performance made for the road. An everyday thrill for those who own them, the Audi RS is engineered and finely tuned for exhilarating performance. It also embodies the kind of fluid, athletic form that makes the daily driver live for track day, or the road ahead.

S

"Drive" can have several meanings. We were driven to craft the Audi S models to blend thrilling acceleration with the daily commute. You are driven by its eye-catching style and invigorating performance. It is driven to transport you on your daily drive—and far beyond.

S line

The look of Audi performance. The S line® option gives a sleek, performance look to select Audi models. So enjoy the double takes and motorsport stance that come with the sculpted lines and aggressively stylish interior appearance and appointments of the S line.

We don't believe in recessive genes.

To those who study it, it has become more and more evident that evolution doesn't have to be slow and steady—it can happen in a single, frenzied burst, instantly making something stronger, more beautiful or fully adapted to even the most challenging environments. The evolutionary leaps found in the Audi performance DNA are proof. Audi doesn't build off the genetic blueprints of past racing championships so much as change what will be technologically and physically possible on the road. It's how power evolves.

Aluminum When the Silver Arrows were king, Auto Union, an Audi ancestor, they were notable for the use of aluminum in their then-uncharted performance machines, up to 350 hp. Auto Union Silver Arrows led to innovative engine design that produced the use of lightweight materials and, ultimately, our use of ASF® aluminum construction.

quattro® In 1977, Audi engineer Jörg Bensinger wondered how a high-performance vehicle would perform with all-wheel drive. Within three years, quattro® all-wheel drive was born, and dominated motorsports. The way into all Audi performance soon found its helped drivers gain confidence even in challenging conditions.

FSI® & TFSI® When FSI technology was introduced into Audi motorsports in 2001, it was a bold move, powering the R8 Le Mans prototype. A twin-turbocharged 3.6-liter V8 with FSI direct injection maximized both power and efficiency. Today, Audi performance cars generated when they hit the accelerator.

S tronic® S tronic is a version of an automated sequential manual transmission first named "S tronic" in the 2005 Audi R10 Le Mans models, which made for smoother acceleration and gear changes as quick as a few hundredths of a second.

Ultra® lightweight technology We introduced the Audi R18 ultra just in time for the 2011 24 Hours of Le Mans. As the technology initiative for the Audi R18 ultra, fiber and magnesium like aluminum, carbon performance models more nimble, more responsive and more progressive.

e-tron® future technology Audi also sees the future of motorsports—electrification. That's one of the reasons why we have brought out the Audi e-tron quattro®, especially now that quattro® is back after an unfair advantage from competition for providing quattro® racecars provide a powerful e-tron controlled performance. It is on this platform that we will build our next trophy case.

Power can feel limitless, even if it follows the laws of motion.

Sure, Isaac Newton may have been right about a lot of things, including the physical laws of the universe, but that doesn't mean we have to like it. So while we're bound to obey the laws of motion, Audi engineers still strive mightily to push the envelope on behalf of our drivers. We know that we can't overcome these laws, but you can enjoy challenging them—it's what iconic power is all about. You can feel the results of our efforts throughout the Audi performance model lineup. Let's just say that we think of our performance vehicles less as lawbreakers than as dynamic followers of Newton's Laws of Motion.



○ Newton's 1st law

A vehicle moving in a straight line at a constant speed will keep such motion until acted on by an external force.

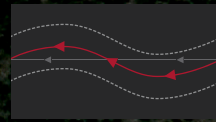

Enviably handling characteristics, achieved through ultra[®] lightweight technology and precise balance, help our performance drivers get the most out of powering through almost any curves they want to own.¹

○ Newton's 2nd law

When a force is applied to a vehicle, the change in motion is proportional to the force divided by the mass of the vehicle.

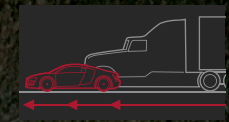

We define our performance less through numbers than through feel. There is nothing like the power distributed by an Audi performance vehicle—pure, effortless and quick. It is accelerated engineering.¹

○ Newton's 3rd law

Every force on a vehicle by another object, such as the ground, is matched by an equal and opposite force on the object by the vehicle.



Design isn't simply for style, it's also needed if Audi performance is to overcome the forces of nature. Design that is streamlined, powerful and focused not only creates momentum in our vehicles—it's an expression of our commitment to performance.

¹ Always obey all speed and traffic laws.

SCULPTING

Audi performance models make the case for functional style. Sculpted large air intakes in the front help channel air to vital cooling components, while differentiated exhaust outlets in the rear lend an unmistakable look and sound to power. We designed both to enhance emotional and technical response.

Style goes beyond the law.

When it comes to the "laws" of design, we chose to be more provocative than obedient. By bringing a courageous style along for the iconic ride, Audi transforms how performance moves you. For the driver, it's about how our sleek, sculpted form engages the senses, how we invite your eye to follow the Roof line into the integrated rear deck-lid spoiler, how the signature Tornado line makes you feel the movement even when in Park. One look, and you'll understand how style gives shape to the emotional core of the moment.

Aluminum-optic accents
+ *design*



LED lighting technology
+ *vision*

unique front fascia
+ *confidence*

RS and S model specific Singleframe® grille
+ *appeal*

seamless laser welds
+ *finish*



LED taillight technology
+ *awareness*

distinctive side sills
+ *appearance*

sport suspension calibration
+ *stance*

RS and S model specific exhaust outlets
+ *audi (Latin for listen)*

Newton's 3rd law ACTION | REACTION

AMAZEMENT

The shorthand for Newton's third law is: For every action, there is an equal and opposite reaction. In the automotive world, that seems too ordinary; our reaction is to use materials and technologies in vehicles like our Audi R8 to challenge convention.

How to say "craft" in a bold new language.

To help our drivers respond to the forces of the universe, we were driven to use innovative materials and technologies in a visionary way. When put to the test in our Audi performance models, they've created a new kind of grammar to articulate how power is channeled and how it performs. By using carbon fiber and aluminum in our body panels and chassis structures, we craft a more powerful, lighter and more precise driving experience. And in crafting a bolder path now, we hope to challenge expectations down the road.



ASF® aluminum construction¹
+ weight reduction and rigidity

carbon fiber-reinforced
polymer (CFRP)¹
+ ultra® lightweight
technology

four rings badge
+ truth in engineering®

dry sump lubrication¹
+ lower center of gravity

magnesium engine compartment
cross-member¹
+ dynamic torsional rigidity and weight reduction

Excessive passion. Streamlined.

Naturally, we sometimes seek to define power. At other times, as when we're testing an Audi facing a wind speed of 87 mph, we look to define the drag coefficient, which might not sound as sexy, but is in reality a measure of just how powerful we can be. And when the test gets up to 186.4 mph, we begin to really understand how aerodynamics affects power. How we cope with drag coefficient, downforce, the slipstream, and air management of vital systems such as engine intake and cooling helps us win the most demanding race on earth: the 24 Hours of Le Mans. But that's not our only goal. It's how our passion for powerful driving dynamics gets streamlined to inspire drivers.¹

AERODYNAMICS

All cars have to overcome the pressure and friction of air when in motion. By designing lines, spoilers and even the undercarriage to the optimum shape of aerodynamic efficiency, Audi helps thrust overcome resistance.



¹ Always obey all speed and traffic laws. ² Features and technologies listed are not available on all models.

GRIP

While on the road, friction is a component of the power your car can distribute. In your car's cabin, friction—also called grip—can help the driver stay better connected to the road, engineered through the design of our sport seats.

The only way we hold you back.

When iconic design needs to take a seat, it better be an Audi sport seat, one where the driver is in total control. With a wraparound fit that helps keep you firmly in place as you hit the throttle, it's a finely tailored, stitched leather seat that's also your secure command center for performance.¹ Everything is within easy reach: your instruments, your shifts, your entertainment. But most of all, this is a seat that makes you one with power.²

integrated head restraints²
+ *comfort*
+ *head support*

diamond cross-stitch pattern²
+ *refinement in craftsmanship*
+ *grip*

seat bolsters
+ *lateral support*
+ *comfort*
+ *positioning*

thigh support²
+ *comfort*
+ *positioning*



POWER

If you are thinking $F = ma$ when you step on the accelerator, you might be overthinking how power is felt. Overcoming opposing forces produces acceleration, but one needs to engage the throttle to break through the physics lesson and emerge into the physical reality of power.

Sharing power with those who earn it.

In the end, we believe that true power is what you feel when behind the wheel. So while horsepower numbers might move you, Audi performance vehicles were engineered to turn raw numbers into something comprehensible and visceral. A track-bred heritage and features like ultra® lightweight technology and more efficient engine design help transform every moment you are in the cockpit into an experience amplified by impressive torque, precise dynamics and the pure thrill of total performance.¹ With numbers like 8,700 rpm and 140 hp per liter, you can quicken a pulse, set a course and feel the flow of energy from your foot to your machine.²



SYMBOL OF POWER



SYMBOL OF POWER



Power density

It's smart to embrace a little light thinking. That's why we design Audi performance engines to be lean. The result is high horsepower per liter—upwards of 130 hp per liter in the Audi S8 and 140 hp per liter in the Audi RS 7. But it's not horsepower alone that defines us—we also take into consideration the concept of power density. We engineer and manufacture proven race-bred engines that not only freely rev as high

as 8,700 rpm, as in the Audi R8 V10, but also remain extremely efficient through the use of innovative features like FSI®, TFSI® and cylinder on demand™ engine efficiency technology.³ Horsepower and efficiency aside, our TFSI engines also develop broad torque curves that peak and plateau just above engine-idling speeds—this is the immense power you actually feel.²

¹ Always obey all speed and traffic laws. ² Specifications listed will differ from model to model. Features and technologies listed are not available on all models. ³ See www.fueleconomy.gov for EPA estimates. Your mileage and emissions data will vary and depend on several factors, including your driving habits and vehicle condition.

HANDLING

Newton tells us that when you push, something pushes back—but sometimes driving doesn't work that way. Dry or inclement weather—that's when you need quattro® all-wheel drive, for optimal grip and power when and where they are most needed.

“Even a trained monkey can win in a quattro®.”

—Walter Röhrl

Long known as the all-wheel-drive standard, quattro® all-wheel drive has also helped us win races all over the world. Some people, like former Audi Sport® driver Walter Röhrl, say that it makes racing almost too easy. From the system's asymmetric torque split that delivers power when and where it's most needed—up to 85% to the rear for straightaway acceleration¹—to the torque vectoring and sport differential that help make cornering more precise and handling more assured, quattro® helps optimize driving performance.² We think you'll enjoy how it helps grip the road and turns your drive into a showcase of progress.³

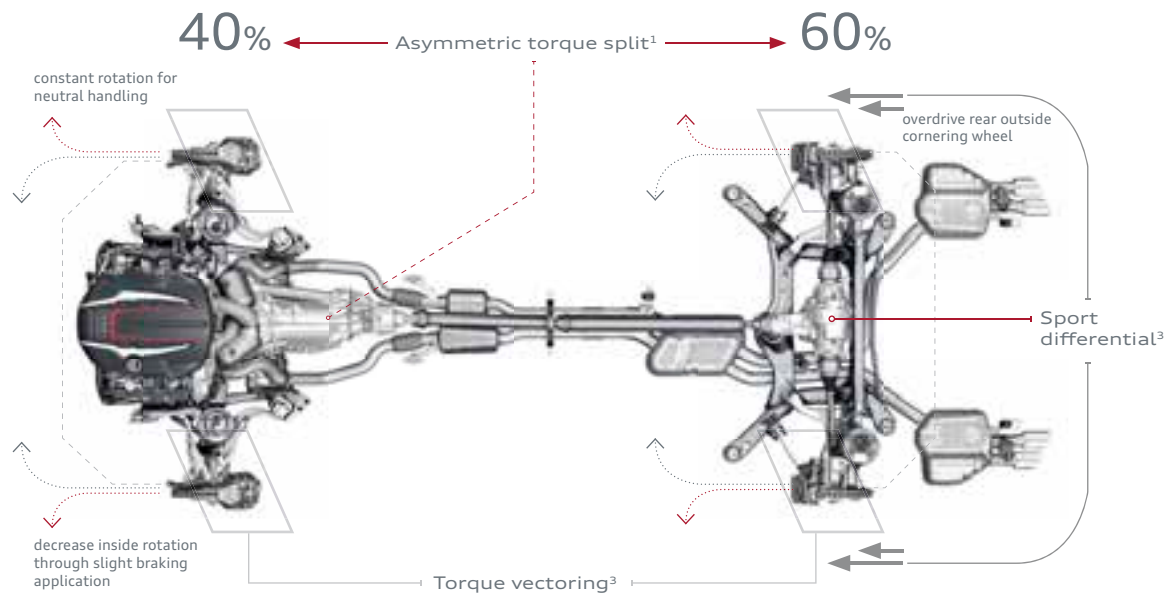

2015 Audi S8 drivetrain shown.

1 Torque split ratio will vary from model to model. 2 Always obey all speed and traffic laws. 3 Features and technologies listed are not available on all models.

Asymmetric torque split

Under normal driving conditions, the center differential splits torque at a ratio of 40:60, front to rear. As conditions change, ratio biases from 70:30 to 15:85, front to rear, are achievable. If extremely low traction exists at either axle, an electronic locking feature can shift up to 100% of available torque to the wheel with the most traction.^{1,2}

Torque vectoring

By independently braking the inside cornering wheels, torque is then transferred to the outside cornering wheels. This intelligent application of power, known as torque vectoring, helps promote neutral handling by calculating the driver's steering input and desired level of acceleration.^{2,3}

Sport differential

To help ensure high cornering stability, the sport differential uses torque vectoring, and then adds to that by mechanically applying additional torque to the outside rear cornering wheel. Through an electrohydraulic multiplate clutch pack and gear-set, the outside rear cornering wheel's speed is increased by as much as 10%.^{2,3}

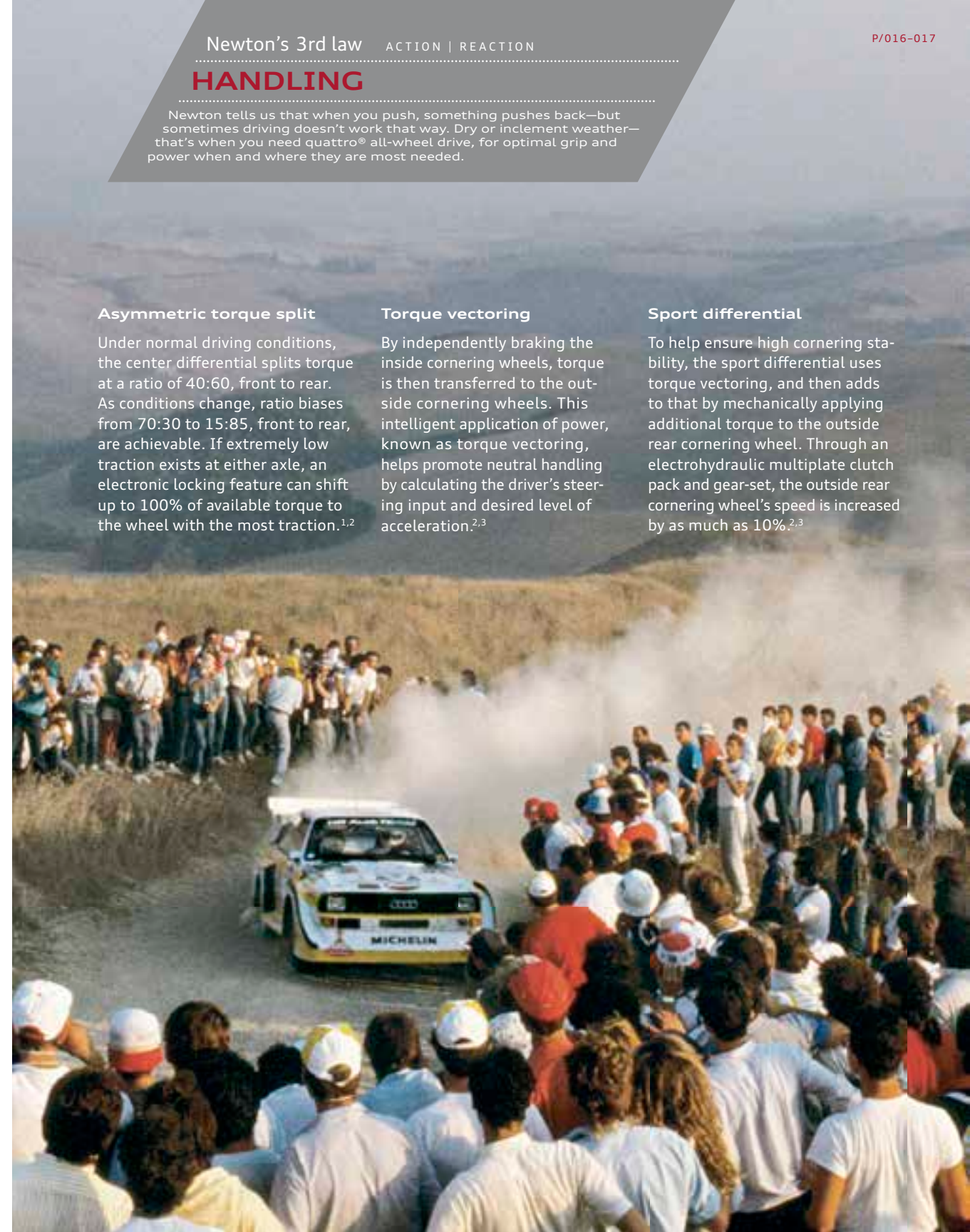

ACCELERATION

Vehicles that are lightweight are the easiest to accelerate. Heavier vehicles require more energy to move and need more force in order to generate similar acceleration. The Audi performance lineup was created to make sizzling performance as powerful and efficient as possible.¹

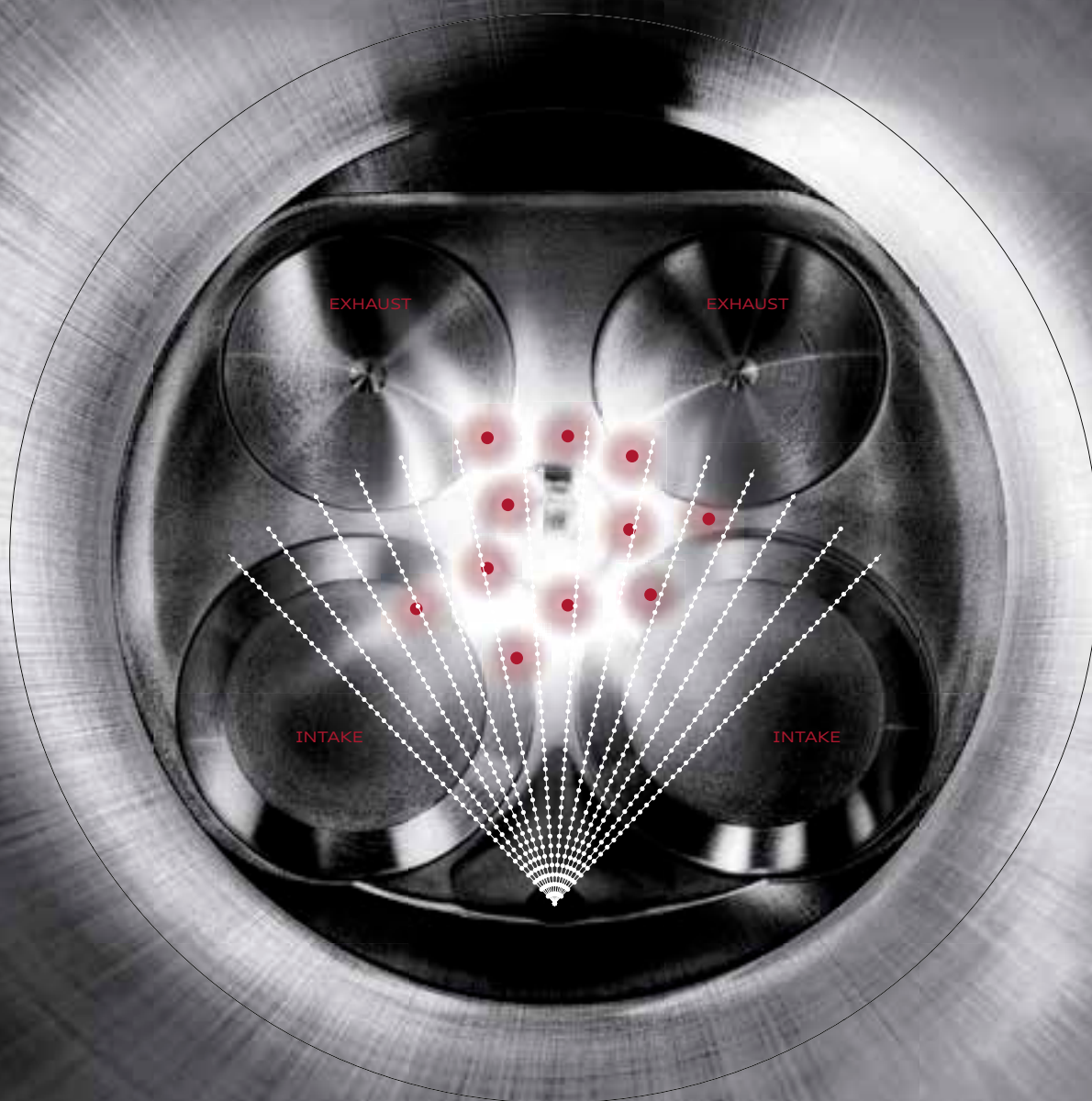
**Ideas that burst through.**

The root of engineering is, of course, the engine. It's the basis of everything we do. So the engines of our Audi performance models not only deliver innovative ideas through performance engineering, but also put the driver at the center of our philosophy.

FSI®

The FSI direct-injection fuel management and delivery system directly injects fuel into the combustion chambers at precisely managed times and depths. What that means for drivers is that a fully homogenized intake charge helps increase power while also reducing fuel consumption and emissions, making efficiency more powerful.¹

TFSI®

At Audi, TFSI represents a combination of two of the brand's core areas of expertise—direct injection and forced induction. By adding forced induction (turbocharging or supercharging) to direct injection technology, the pressurized intake charge is cooled by directly injected fuel, thus helping achieve efficiency and performance combined with higher compression ratios—previously only attainable by naturally aspirated engines.^{1,2}

cylinder on demand™

In low-load situations like highway cruising, the Audi RS 7, S8, S7 and S6 make use of cylinder on demand engine efficiency technology, which shuts down cylinders for greater efficiency.¹ Four cylinders can be deactivated when they aren't needed. And once full power is required, all cylinders fire back to life almost imperceptibly.²

Valve lift and variable valve timing

It isn't easy to mix a perfect cocktail, especially when the only ingredients are air, fuel and a spark. Sliding electromagnetic sleeves on the camshafts adjust the lift, duration and timing of the intake and exhaust valves to help maximize each combustion cycle. The result is increased torque and less fuel consumption.^{1,2}

1. See www.fueleconomy.gov for EPA estimates. Your mileage and emissions data will vary and depend on several factors, including your driving habits and vehicle condition. 2. Features and technologies listed are not available on all models.

TRANSFER OF POWER

Newtons are a unit of measure used to determine the force required to move an object. As we move up through the gears, we're working hardest at the moment of acceleration, then maintaining power through seamless shifting, optimizing our output of newtons.

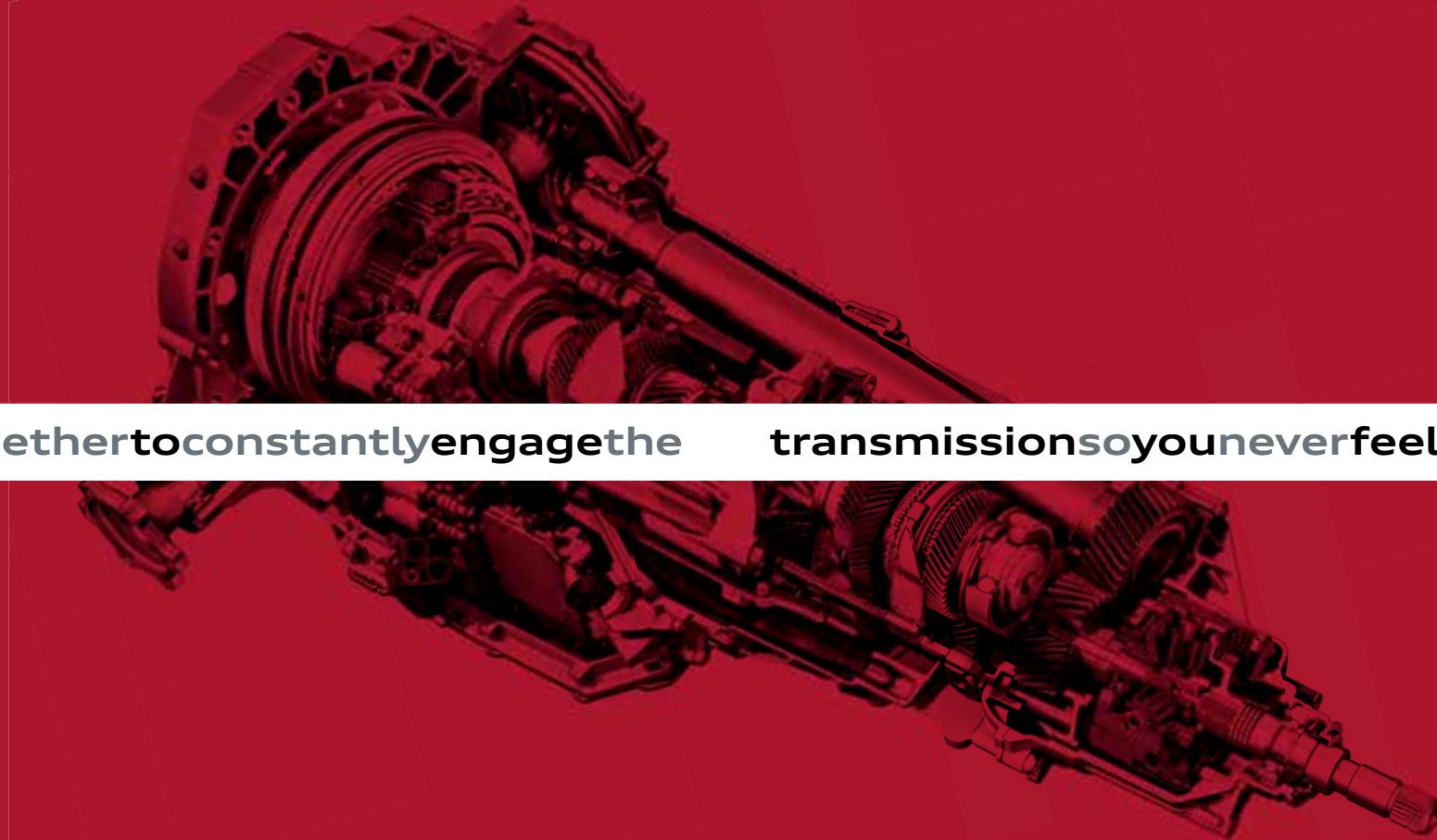

Dual clutches work together to constantly engage the transmission so you never feel a break in acceleration.

The boldest drivers always enjoy power without pause. Which is good, because that's our thinking behind the transmission offerings in Audi performance vehicles. It's why power can be intimately expressed by your hands with the use of steering wheel-mounted shift paddles or a console-mounted manual shifter.¹ However you engage them, our transmissions are sure to deliver, guaranteeing that power will be felt in a virtually uninterrupted expression of progressive performance.

S tronic® transmission

The Audi R8, RS 5, S7, S6, S5, S4, S3 and TTS models change gears in a few hundredths of a second with the S tronic dual-clutch transmission, delivering automatic convenience with manual sportiness. The available launch control system heightens acceleration through precisely managed engine speed and an automated clutch release.^{1,2}

Tiptronic® transmission

In the Audi RS 7, S8 and SQ5, power is transferred through an eight-speed Tiptronic® automatic transmission. With a large spread of gear ratios, this transmission helps optimize the engine speed for responsive power delivery and enhanced efficiency.³ The Dynamic Shift Program (DSP) helps provide smooth and sporty gear changes.

Manual transmission

Audi R8, S5 Coupe and S4 models offer a manual transmission to put the driver at center stage. Master the timing, feel and art of the perfect shift through a six-speed manual transmission with a precise, short, clearly defined shifter throw. As an added benefit, a self-adjusting clutch moderates the clutch release load for consistent shifting performance.

¹ Features and technologies listed are not available on all models. ² Always obey all speed and traffic laws. ³ See www.fueleconomy.gov for EPA estimates. Your mileage and emissions data will vary and depend on several factors, including your driving habits and vehicle condition.

BRAKING

This law is never more evident than when inertia is interrupted—as when you brake. Stopping vehicle mass and momentum involves an enormous amount of force, and the by-product is expressed in heat. It's the heat we can handle.

Handling the heat in the coolest way possible.

Let's just say that we can take the heat. An extraordinary amount, in fact, due to the technologies we employ throughout our Audi Sport® performance line. As a perfect counterbalance in performance driving, our cast-iron and Audi ceramic braking technologies are far from conventional.^{1,2} By reducing the dynamic weight and managing the dissipation of heat through cross-drilled ventilation, wave-cut design or the use of carbon-ceramic composites, our brakes deliver increased resistance to fade, ultimately helping to increase braking performance.²

Carbon fiber-reinforced ceramics can withstand temperatures up to

1,830°F

sophisticated ventilation and perforation for optimal cooling

in contrast to cast-iron brake discs, carbon ceramic brake discs are lighter and more resistant to fading

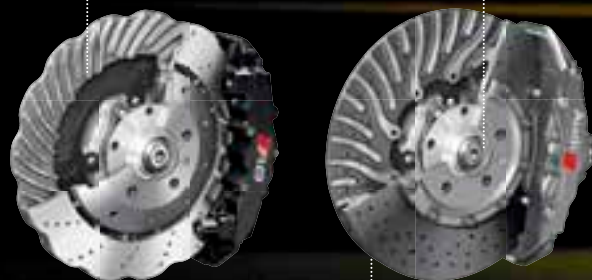

wave-cut design for a 6.61-lb weight reduction compared to traditional cast-iron brake rotors²

up to an 8.82-lb weight reduction for each front brake rotor compared to traditional cast-iron brakes²



Newton's 2nd law $MASS | F = ma$

LIGHTWEIGHT

A lower mass needs less force to accelerate. That also means it needs less force to stop, making braking easier. There are many benefits of lightweight design—including more precise cornering and greater engine efficiency.¹

Efficiency is a natural selection.

As engineers, we don't add more of something when less will be more effective. For inspiration, we looked to nature, and discovered the fascinating design of bamboo. Lightweight yet strong, bamboo is a great example of natural efficiency. Taking our cues from it, our design adds strength at the conjoined areas (nodes), while the structural burdens in some aluminum extrusions (shafts) help to lower the overall weight. It allows for both rigidity and flexibility where each is most needed, and for efficiency overall.¹ This kind of progressive thinking seems like a natural selection to us.²



NODE
SHAFT
NODE

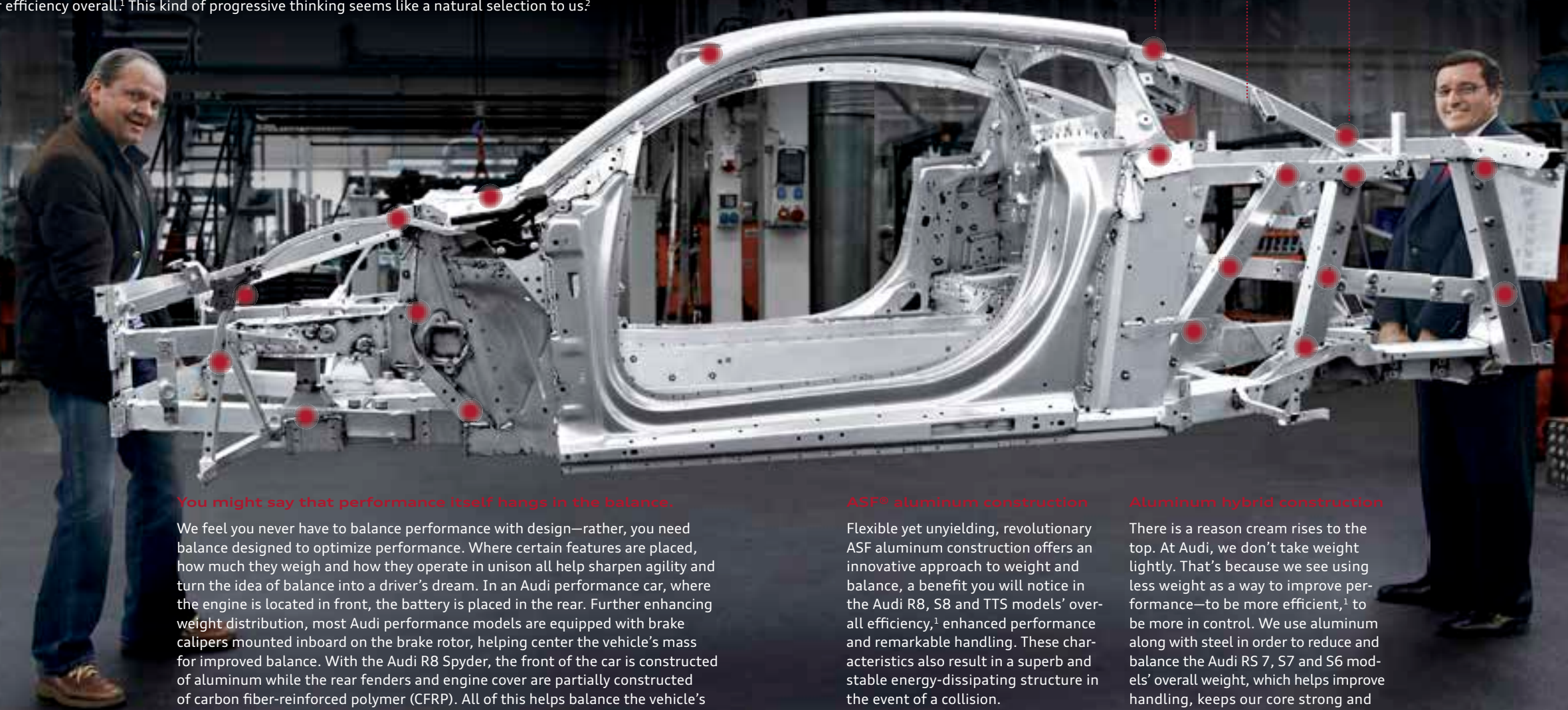

You might say that performance itself hangs in the balance.

We feel you never have to balance performance with design—rather, you need balance designed to optimize performance. Where certain features are placed, how much they weigh and how they operate in unison all help sharpen agility and turn the idea of balance into a driver's dream. In an Audi performance car, where the engine is located in front, the battery is placed in the rear. Further enhancing weight distribution, most Audi performance models are equipped with brake calipers mounted inboard on the brake rotor, helping center the vehicle's mass for improved balance. With the Audi R8 Spyder, the front of the car is constructed of aluminum while the rear fenders and engine cover are partially constructed of carbon fiber-reinforced polymer (CFRP). All of this helps balance the vehicle's center of gravity, which in turn helps make handling more dynamic and true.²

ASF® aluminum construction

Flexible yet unyielding, revolutionary ASF aluminum construction offers an innovative approach to weight and balance, a benefit you will notice in the Audi R8, S8 and TTS models' overall efficiency,¹ enhanced performance and remarkable handling. These characteristics also result in a superb and stable energy-dissipating structure in the event of a collision.

Aluminum hybrid construction

There is a reason cream rises to the top. At Audi, we don't take weight lightly. That's because we see using less weight as a way to improve performance—to be more efficient,¹ to be more in control. We use aluminum along with steel in order to reduce and balance the Audi RS 7, S7 and S6 models' overall weight, which helps improve handling, keeps our core strong and enhances overall performance.

¹ See www.fueleconomy.gov for EPA estimates. Your mileage and emissions data will vary and depend on several factors, including your driving habits and vehicle condition.
² Features and technologies listed are not available on all models.

DRIVING DYNAMICS

The third law talks about things that Audi drive select addresses with a push of a button. Through different modes of driving dynamics and performance options, Audi drive select helps you meet the equal and opposite forces of the road on your own terms.

Pit crews at the touch of a button. ▯

We talk a lot about power, performance, technology—the things that make Audi distinctive. Available Audi drive select adds to that by helping make your own driving experience distinctive, almost like a pit crew that is always at hand. This is customizable technology for driving that helps you control the characteristics of your drive through finely defined precision handling, increasingly taut and precise throttle response or a more relaxed feel in the cockpit. Choose from Dynamic, Comfort, Auto or Individual modes to configure the throttle, transmission, steering and suspension settings along with the sport differential to respond to your desires, or the conditions.¹ It's your choice. It helps bring out the best of your performance vehicle, of course. But it also helps bring out the best in you, without needing an entire crew to tune your driving characteristics for the road ahead.

Dynamic mode

More precise steering, more responsive throttle and quicker shifting focus performance while stiffer suspension gives this setting an uncompromising feel.¹

Comfort mode

This setting provides a silkier, more relaxed feel for steering, throttle, and transmission inputs while also providing a softer suspension setting to maximize a more comfortable ride.¹

Auto mode

Auto mode helps deliver the best of both worlds by automatically adjusting to the optimal settings for a seamless combination of comfort and handling.¹

Individual mode

Take the turn your way. Adjust the steering, throttle response and suspension to your style, and this setting will be yours whenever you choose it.¹

Here's where performance comes full circle. ▯

This is how you feel the power that's expressed when you are in the driver's seat. Through superior handling and balance that help keep the power where it belongs, Audi suspension systems help you define performance in the boldest terms.

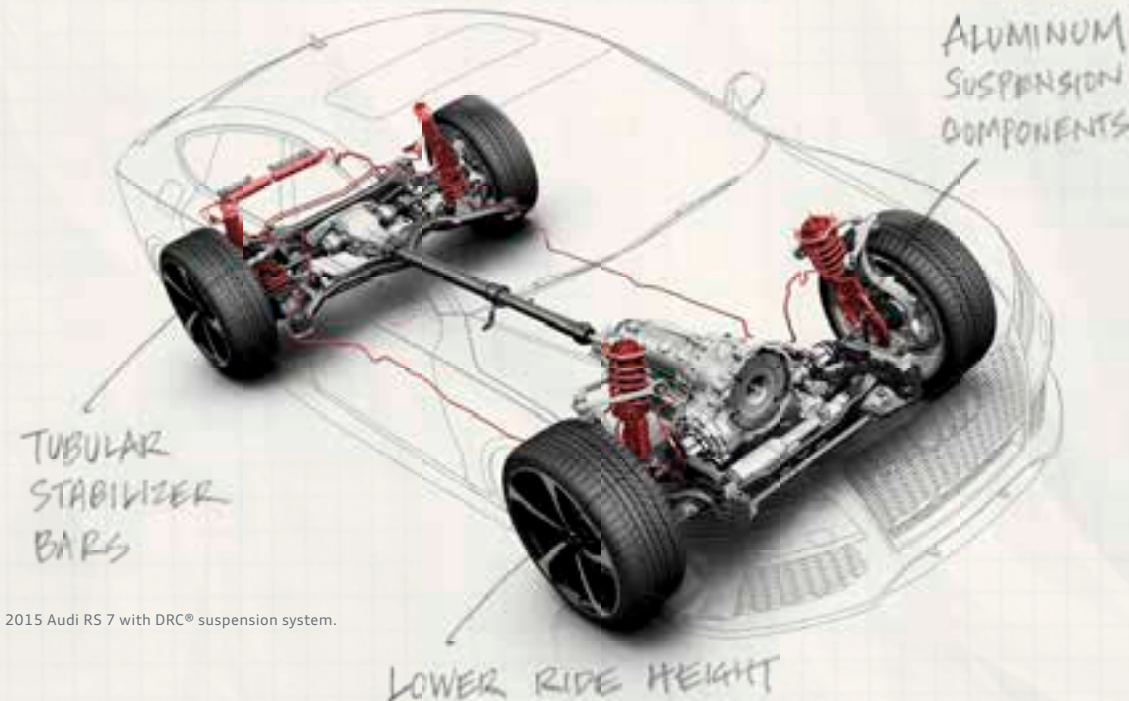

2015 Audi RS 7 with DRC® suspension system.

Sport suspension

By reducing the ride height, Audi sport suspension calibration helps to truly define the responsive, quick-to-the-touch handling that sets Audi performance models apart. We've designed the springs and dampers with firmer tuning to help optimize contact with the road surface, letting you put meaning to the word *agility*.

Audi magnetic ride

Instead of conventional damper oil, the Audi R8, TTS and S3, when equipped, have shocks and struts that are filled with a special fluid, where viscosity can be controlled by an electromagnetic charge. Audi magnetic ride suspension helps damping forces continuously adjust to current driving conditions to provide the right amount of suspension firmness in a fraction of a second.¹

Audi adaptive air suspension

Blending dynamic handling with true comfort, Audi RS 7, S8, S7 and S6 models offer sport-tuned adaptive air suspension that allows for speed-dependent lowering of the body, resulting in a lower center of gravity, which helps significantly improve your directional stability. Speed or driver-selectable control logic adjusts the air suspension springs at all four wheels, adjusting the suspension in milliseconds.¹

DRC® suspension system

Available in the RS 7, DRC connects the shock absorbers diagonally to the ones on the opposite side of the car through a central valve which helps provide oil for additional damping force on compressed shocks. This is a potent performance system, helping hone both precision handling and vehicle stability. The damper settings can be adjusted, according to conditions and personal preferences, via the Audi drive select system.

¹ Features and technologies listed are not available on all models.

ROTATIONAL MOMENTUM

In the end, Newton's Laws of Motion deal with balance. Audi engineers work tirelessly to channel inertia into a fully expressed form of power and control, so the inertia exerted by rotational momentum finds the balance it needs to work properly, in context of the drive.



translatory motion

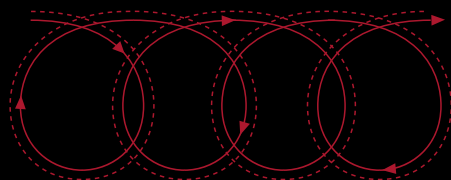

rotational momentum

Here's a case where knowing the law puts us on a more powerful path. By focusing on optimizing the rotational momentum in Audi performance models, we make more responsive and efficient vehicles?



lightweight alloy wheel // reduced wheel wall thickness for less rotational weight



carbon ceramic rotor¹ // reduces rotational weight by up to 8.82 lb each, compared to traditional rotors

Acceleration // The more weight the component has, the more energy it takes to accelerate it (translatory motion) and overcome its inertia (rotational momentum). Deceleration // The more weight the component has, the more force it takes to overcome its inertia (rotational momentum) and decelerate its mass (translatory motion).

¹ Features and technologies listed are not available on all models. ² See www.fueleconomy.gov for EPA estimates. Your mileage and emissions data will vary and depend on several factors, including your driving habits and vehicle condition.

Intensity behind the wheel.

The stories tell you how and why Audi Sport® performance represents the soul of automotive engineering. But they won't move you the way our models will. The models are more than the heart of Audi performance, they are a necessary reminder of what it takes to perfect the art of living a more intense life behind the wheel.



RS **RS 7** **RS 5**

S8 **S7** **S6** **S5** **S4** **S3** **TT S** **SQ5**

The driver's choice. By acclamation and exclamation.

Every inch a supercar, the Audi R8 defines the endless possibilities and incredible performance that Audi produces throughout its lineup. But more than that, the R8 stands as the dynamic, proud parent, passing on the legacy of its design, its power, its components and matchless materials throughout its Audi Sport® progeny. It may strike you like a thunderbolt when you first see it, it may seem immortal, but it is also every inch an Audi performance car. As such, it is the manifestation of desire, but also the blueprint for the dynamic models that follow. Discover these legendary performance cars and how they push the boundaries of the physical reality of Newton's Laws of Motion.

R8

/ R8 COUPE / R8 SPYDER /



2015 Audi R8 V10 Coupe shown in Ice Silver metallic.

V8 or V10 FSI® engine
430 to 550 horsepower
0-60 mph in 3.3 to 4.6 seconds
Top track speed of 186 to 198 mph¹

P/350-031

R8



2015 Audi R8 V10 Spyder shown in Daytona Gray pearl.



2015 Audi R8 V10 Coupe and R8 V10 Spyder shown with available equipment.

¹ Always obey all speed and traffic laws.



R8

/ R8 COUPE / R8 SPYDER /

The 2015 Audi R8 is just as exhilarating when driven on an ordinary road as it is on an extraordinary track. It's a prime example of how our racing DNA is directly transferred to our production vehicles—from the exceptional performance of the R8 V8 with its 430 hp and 317 lb-ft of torque to the stunning R8 V10 plus, whose FSI® direct-injected DOHC V10 belts out 550 hp and 398 lb-ft of torque with a maximum engine speed of 8,700 rpm. And with each model featuring ultra® lightweight technology-inspired ASF® aluminum construction, legendary quattro® all-wheel drive, and a six-speed manual or available seven-speed S tronic® dual-clutch transmission, you can bet that their performance is like nothing you've experienced before.¹

2015 Audi R8 V10 Coupe shown with Titanium Gray Leather and available equipment.



ENGINE // 5.2-liter FSI® V10 engine developing 550 hp and 398 lb-ft of torque
5.2-liter FSI® V10 engine developing 525 hp and 391 lb-ft of torque
4.2-liter FSI® V8 engine developing 430 hp and 317 lb-ft of torque

DRIVETRAIN // quattro® all-wheel drive, six-speed manual transmission or an available seven-speed S tronic® dual-clutch transmission

CHASSIS // R8 tuned sport suspension, Audi magnetic ride (not available on R8 V10 plus)

BRAKES // 14.4" ventilated wave design front disc brakes with R8 logo, 14.0" ventilated wave design rear disc brakes or available Audi ceramic brakes (Audi ceramic brakes are standard on R8 V10 plus)

PERFORMANCE // R8 V10 plus—Top track speed of 198/197 mph (manual/S tronic).¹ acceleration 0–60 mph in 3.7/3.3 seconds (manual/S tronic). R8 V10—Top track speed 196/195 mph (Coupe, manual/S tronic) and 194/193 mph (Spyder, manual/S tronic).¹ acceleration 0–60 mph in 3.8/3.4 seconds (Coupe, manual/S tronic), 4.0/3.6 seconds (Spyder, manual/S tronic). R8 V8—Top track speed of 188/186 mph (Coupe, manual/S tronic) and 186 mph (Spyder).² acceleration 0–60 mph in 4.4/4.2 seconds (Coupe, manual/S tronic) and 4.6/4.4 seconds (Spyder, manual/S tronic)¹

¹ Always obey all speed and traffic laws.

It is the kind of arrival that announces itself. The Audi RS 7 comes into the world not so much unveiled as unleashed. A sleek, powerful presence of sophisticated design and roaring performance makes it clear that this is an unmistakable, undisguised automotive statement. At 560 hp, through a turbocharged 4.0-liter TFSI® V8 engine, it brings thundering performance, and with quattro® all-wheel drive with sport differential and RS 7 tuned Audi adaptive air suspension or an available DRC® suspension system, that power is never unrefined. We designed it to sit slightly lower to the ground, and added larger air intakes and a sportier chin spoiler to give it an even sharper sense of fluidity. Finally, the available sport exhaust brings the thunderous sonic punch of a true performer.

4.0-liter turbocharged TFSI® V8 engine
560 horsepower
0-60 mph in 3.7 seconds
Top track speed of 174 mph¹

RS 7



2015 Audi RS 7 shown in Daytona Gray pearl with available equipment.

¹ Top track speed is electronically limited in the U.S. Always obey all speed and traffic laws.



RS 7

The potency of the Audi RS 7, in style and in performance, is unmistakable, even at first glance. But that's not to say there are no surprises. With cylinder on demand™ engine efficiency technology, which shuts down four cylinders when power and out-and-out performance are not required, the RS 7 has the ability to use less fuel when it's engaged.² The RS 7 is luxury performance personified, with signature Audi fit and finish throughout the interior, technology to spare and style to burn. It is desire in its most stunning form.

2015 Audi RS 7 shown with Black leather and available equipment.

- ENGINE // 4.0-liter turbocharged TFSI® V8 engine developing 560 hp and 516 lb-ft of torque with RS oval exhaust and available sport exhaust system with Black outlets
- DRIVETRAIN // quattro® all-wheel drive with sport differential, eight-speed Tiptronic® automatic transmission
- CHASSIS // RS 7 tuned Audi adaptive air suspension or available DRC® suspension system, Audi drive select and available dynamic steering
- BRAKES // 15.4" ventilated wave design front disc brakes with RS logo, 14.0" ventilated wave design rear disc brakes
- PERFORMANCE // Top track speed of 174 mph¹; acceleration 0-60 mph in 3.7 seconds

1. Top track speed is electronically limited in the U.S. Always obey all speed and traffic laws. 2. 16 city/27 highway/19 combined mpg (2015 Audi RS 7 4.0T with eight-speed Tiptronic® automatic transmission and quattro® all-wheel drive). EPA estimates. Your mileage will vary and depends on several factors, including your driving habits and vehicle condition.



The Audi RS 5 doesn't come with a sign that says "For Serious Drivers Only." It doesn't have to—everyone just knows. Factory-tuned and stunningly executed, and with a Cabriolet variant, this progressive performance car showcases an aggressive front end, wide wheel arches and adaptive rear spoiler (Coupe only). But the power is what really makes this a definitive statement of Audi Sport® performance. It features a 4.2-liter FSI® V8 engine that produces 450 hp, along with a seven-speed S tronic® dual-clutch transmission that helps funnel power to the road through nearly seamless shifts and the legendary quattro® all-wheel drive. The result? An Audi RS 5 sprinting from 0 to 60 mph in 4.5 to 4.9 seconds with a thundering affirmation from the RS-exclusive oval exhaust outlets.¹

4.2-liter FSI® V8 engine
450 horsepower
0-60 mph in 4.5 to 4.9 seconds
Top track speed of 174 mph¹

RS 5

/ RS 5 COUPE / RS 5 CABRIOLET /



2015 Audi RS 5 Coupe shown in Ibis White with available equipment.



2015 Audi RS 5 Cabriolet shown in Sepang Blue pearl with available equipment.



¹ Top track speed is electronically limited in the U.S. Always obey all speed and traffic laws.



2015 Audi RS 5 Coupe shown with Lunar Silver leather and available equipment.



RS 5

/ RS 5 COUPE / RS 5 CABRIOLET /

Not to be outdone by the exterior design, the Audi RS 5 interior is a statement of design infused with performance. With a driver-centric cockpit informed with touches of Fine Nappa leather on the seats and door armrests, twelve-way power front sport seats emblazoned with RS 5 contrasting embroidery, Carbon Fiber or available Aluminum Race decorative inlays, and a multifunction flat-bottom sport steering wheel with shift paddles, the RS 5 is built with a purpose. Making your purpose clear—to drive one.

ENGINE // 4.2-liter FSI® V8 engine developing 450 hp and 317 lb-ft of torque with RS oval exhaust and available sport exhaust system with Black outlets

DRIVETRAIN // quattro® all-wheel drive with sport differential, seven-speed S tronic® dual-clutch transmission

CHASSIS // RS 5 tuned sport suspension, Audi drive select and available dynamic steering

BRAKES // 14.4" ventilated wave design front disc brakes with RS logo, 12.8" ventilated wave design rear disc brakes or available 14.9" Audi ceramic front disc brakes

PERFORMANCE // Top track speed of 174 mph¹; acceleration 0-60 mph in 4.5 seconds (Coupe) and 4.9 seconds (Cabriolet)

¹ Top track speed is electronically limited in the U.S. Always obey all speed and traffic laws.



For those who strive for power on a grand scale, we'd like to introduce the new Audi S8. From the 4.0-liter TFSI® V8 engine delivering an astonishing 520 hp and 481 lb-ft of torque, announced through the pure power of the available sport exhaust, to the ingenious fuel-saving cylinder on demand™ engine efficiency technology, the reimagined S8 is as athletic as it is innovative.¹ And with dramatic driving characteristics made possible by the signature ASF® aluminum construction and quattro® all-wheel drive with sport differential, the S8 confidently delivers an ultrapowerful sports luxury experience. And more.

4.0-liter turbocharged TFSI® V8 engine
520 horsepower
0-60 mph in 3.9 seconds
Top track speed of 155 mph²

S8



2015 Audi S8 shown in Daytona Gray pearl with available equipment.

¹ 17 city/27 highway/20 combined mpg (2015 Audi S8 4.0T with eight-speed Tiptronic® automatic transmission and quattro® all-wheel drive). EPA estimates. Your mileage will vary and depends on several factors, including your driving habits and vehicle condition. ² Top track speed is electronically limited in the U.S. Always obey all speed and traffic laws.



S8

To truly set a new standard of luxury performance, you need luxury and performance to be equally unmistakable. So while the new Audi S8 wears performance on its sleeve, it also features unsurpassed luxury at its core. Sumptuous 22-way sport comfort front seats with Valcona leather and contrast diamond stitching enthrall the driver and front passenger, while the Alcantara® headliner and Carbon Atlas decorative inlays add to its Audi performance character. By the time you've discovered the unparalleled convenience of MMI® touch and Audi connect® with Google Earth™ satellite imagery, you've found a sanctuary for your soul as much as a thrill for your right foot.^{1,2}



2015 Audi S8 shown with Audi design selection, Vermont Brown leather and available equipment.

ENGINE // 4.0-liter turbocharged TFSI® V8 engine developing 520 hp and 481 lb-ft of torque with S quad exhaust and available sport exhaust system with Black outlets

DRIVETRAIN // quattro® all-wheel drive with sport differential, eight-speed Tiptronic® automatic transmission

CHASSIS // S8 tuned Audi adaptive air suspension, Audi drive select and dynamic steering

BRAKES // 15.7" ventilated front disc brakes with S8 logo, 14.0" ventilated rear disc brakes

PERFORMANCE // Top track speed of 155 mph³, acceleration 0-60 mph in 3.9 seconds

1. Always pay careful attention to the road, and do not drive while distracted. The features and technologies discussed are optional, may require an additional subscription with separate terms and conditions, and should be used only when it is safe and appropriate. The Wi-Fi® hotspot feature is intended for passenger use only. 2. Always obey all speed and traffic laws. 3. Top track speed is electronically limited in the U.S. Always obey all speed and traffic laws.

Certain drivers know that sometimes it's a good thing to blow everything out of proportion. Like design. Like performance. Like innovation. In that spirit, think of our Audi S7 as a powerful piece of performance art. It's a design and engineering statement that takes proportion and stretches it along an iconic Tornado line that, once followed from the hood, enters new territory about the time you reach the rear. Bold and sophisticated, the sloping tailgate of this performance five-door coupe becomes the signature cue for this most stylish expression of Audi performance.

S7

4.0-liter turbocharged TFSI® V8 engine
420 horsepower
0-60 mph in 4.5 seconds
Top track speed of 155 mph¹

P/046-047

S7



2015 Audi S7 shown in Ice Silver metallic with available equipment.

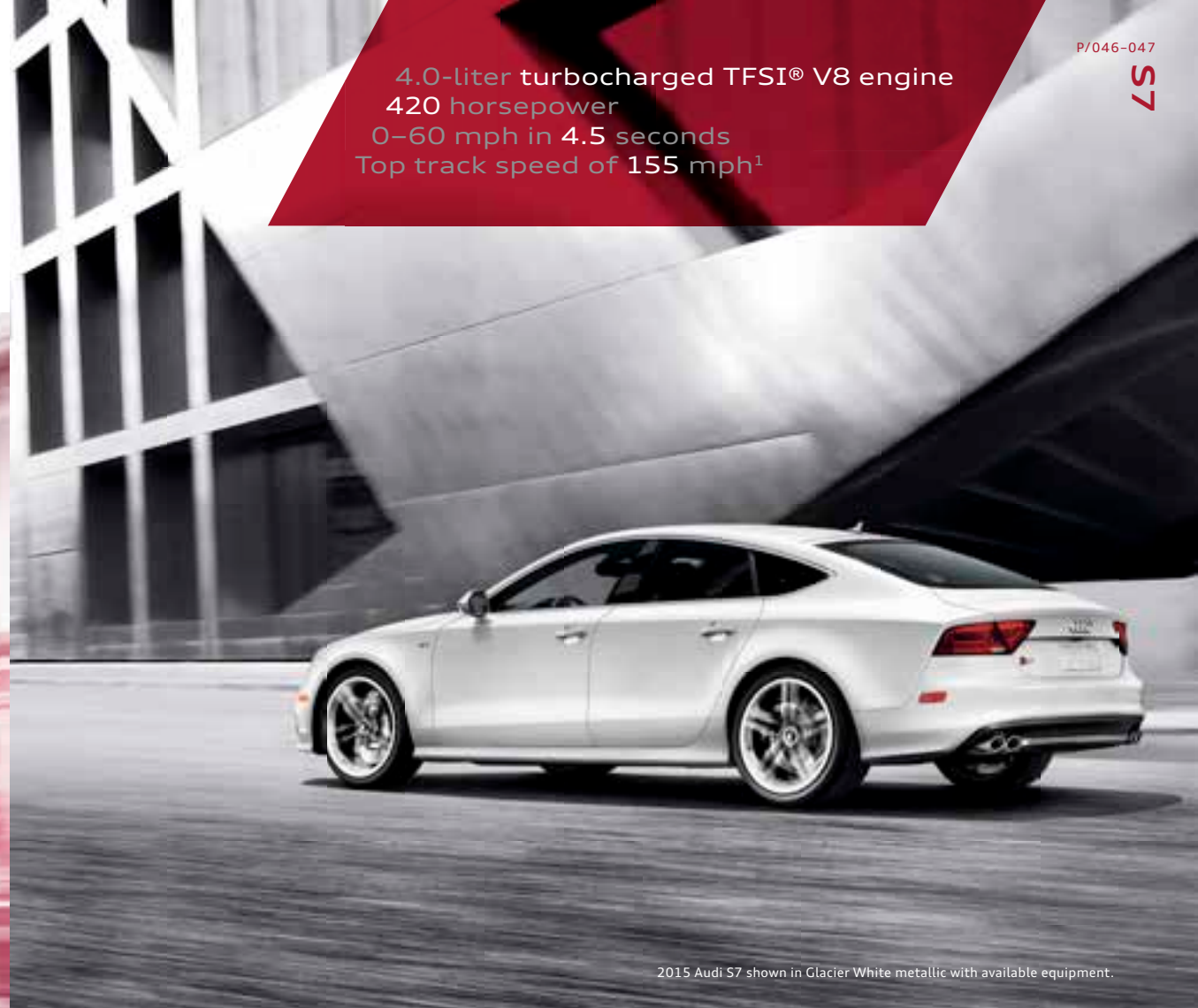

2015 Audi S7 shown in Glacier White metallic with available equipment.



¹ Top track speed is electronically limited in the U.S. Always obey all speed and traffic laws.

S7

Just because the Audi S7 is design-forward doesn't mean power lags behind. The 420-hp 4.0-liter TFSI® V8 takes full advantage of its aerodynamic shape to shred 0- to 60-mph times, while driving in full control with permanent quattro® all-wheel drive.¹ And when you are simply cruising, the cylinder on demand™ engine efficiency technology uses only the piston power that's necessary, helping make your drive more efficient.² The Audi S7 is finely designed performance that sizzles on the pavement, while the look burns even when standing still.



2015 Audi S7 shown with Black leather and available equipment.

- ENGINE // 4.0-liter turbocharged TFSI® V8 engine developing 420 hp and 406 lb-ft of torque with S quad exhaust outlets
- DRIVETRAIN // quattro® all-wheel drive with sport differential, seven-speed S tronic® dual-clutch transmission
- CHASSIS // S7 tuned Audi adaptive air suspension, Audi drive select
- BRAKES // 15.7" ventilated front disc brakes with S7 logo, 14.0" ventilated rear disc brakes
- PERFORMANCE // Top track speed of 155 mph³; acceleration 0-60 mph in 4.5 seconds

1 Always obey all speed and traffic laws. 2 17 city/27 highway/20 combined mpg (2015 Audi S7 4.0T with seven-speed S tronic® dual-clutch transmission and quattro® all-wheel drive). EPA estimates. Your mileage will vary and depends on several factors, including your driving habits and vehicle condition. 3 Top track speed is electronically limited in the U.S. Always obey all speed and traffic laws.

The Audi S6 isn't here to play nice, no matter how composed it feels. In a lineup of progressive performance, you have to stand out in your own way. Effortlessly unleashing its 4.0-liter TFSI® V8 engine to produce an unrelenting 420 hp helps give you a seemingly endless stream of power.¹ But what is power without control? That's where the legendary quattro® all-wheel drive with sport differential and S6 tuned Audi adaptive air suspension come into play. Never have stature, sophistication and sport felt so playfully powerful.

S6

4.0-liter turbocharged TFSI® V8 engine
420 horsepower
0-60 mph in 4.5 seconds
Top track speed of 155 mph¹

P/050-051

S6



2015 Audi S6 shown in Ice Silver metallic with available equipment.

¹ Top track speed is electronically limited in the U.S. Always obey all speed and traffic laws.



2015 Audi S6 shown with Lunar Silver leather and available equipment.



S6

The driver should immediately sense the difference performance luxury makes. Seductive yet assertive, the Audi S6 features an interior that captures the imagination through signature sport seats with integrated head restraints covered in Valcona leather and accented by available Carbon Atlas or a choice of decorative wood inlays on the dashboard, center console and door panels. The S6 also delivers available driver assistance features like a night vision assistant with pedestrian detection and MMI® navigation plus, along with the connectivity of Audi connect®². The S6 doesn't simply deliver on luxury, it gives drivers a new perspective on the world around them.

ENGINE // 4.0-liter turbocharged TFSI® V8 engine developing 420 hp and 406 lb-ft of torque with S quad exhaust outlets

DRIVETRAIN // quattro® all-wheel drive with sport differential, seven-speed S tronic® dual-clutch transmission

CHASSIS // S6 tuned Audi adaptive air suspension, Audi drive select

BRAKES // 15.7" ventilated front disc brakes with S6 logo, 14.0" ventilated rear disc brakes

PERFORMANCE // Top track speed of 155 mph,¹ acceleration 0-60 mph in 4.5 seconds

¹ Top track speed is electronically limited in the U.S. Always obey all speed and traffic laws. ² Always pay careful attention to the road, and do not drive while distracted. The features and technologies discussed are optional, may require an additional subscription with separate terms and conditions, and should be used only when it is safe and appropriate. The Wi-Fi® hotspot feature is intended for passenger use only.



Introducing the sports car's sports car. The Audi S5. The S5 brings more to the road, from its LED daytime running light design to the Singleframe® grille. Its iconic style never lets you forget the performance potential of the 3.0-liter TFSI® V6 engine that delivers a substantial 333 hp, all funneled to the road through a six-speed manual (Coupe only) or available seven-speed S tronic® dual-clutch transmission and quattro® all-wheel drive. With already brilliant driving dynamics and tight sport suspension calibration that puts you in total control, the S5 is ready for the most challenging drive in the world. Yours.

S5

/ S5 COUPE / S5 CABRIOLET /



2015 Audi S5 Coupe shown in Florett Silver metallic.

3.0-liter supercharged TFSI® V6 engine
333 horsepower
0-60 mph in 4.9 to 5.3 seconds
Top track speed of 155 mph^{1,2}

P/054-055

S5



2015 Audi S5 Cabriolet shown in Ibis White with available equipment.



1. Top track speed is electronically limited in the U.S. Always obey all speed and traffic laws.
2. Top track speed is limited to 130 mph when equipped with all-season tires (Coupe models only).



2015 Audi S5 Coupe shown with Black/Lunar Silver leather and available equipment.

S5

/ S5 COUPE / S5 CABRIOLET /

The power and performance get the Audi S5 noticed, but the interior design generates a deep respect too. Signature sport design elements outfit the driver-centric cabin, while available Audi connect® with a Wi-Fi® hotspot for up to eight passenger devices helps you remain close even when you are far from it.¹ Available in Coupe or Cabriolet form, the S5 is the total package—stylish, luxurious, progressive and powerful. We like to think it's the kind of sports car that other sports cars dream of as the ideal.



2015 Audi S5 Cabriolet shown with Black/Magma Red leather and available equipment.

- ENGINE // 3.0-liter supercharged TFSI® V6 engine developing 333 hp and 325 lb-ft of torque with S quad exhaust outlets
- DRIVETRAIN // quattro® all-wheel drive, available sport differential, six-speed manual transmission (Coupe only) or an available seven-speed S tronic® dual-clutch transmission
- CHASSIS // S5 tuned sport suspension, Audi drive select and available dynamic steering
- BRAKES // 13.6" ventilated front disc brakes with S5 logo, 13.0" ventilated rear disc brakes
- PERFORMANCE // Top track speed of 155 mph^{2,3} acceleration 0-60 mph in 4.9 seconds (Coupe) and 5.3 seconds (Cabriolet)

¹ Always pay careful attention to the road, and do not drive while distracted. The features and technologies discussed are optional, may require an additional subscription with separate terms and conditions, and should be used only when it is safe and appropriate. The Wi-Fi® hotspot feature is intended for passenger use only. ² Top track speed is electronically limited in the U.S. Always obey all speed and traffic laws. ³ Top track speed is limited to 130 mph when equipped with all-season tires (Coupe models only).

With "classic sports sedan" written all over the Audi S4, we know you'll be writing your own story together. For starters, style isn't prologue. It's intrinsic to the story. Beautifully rendered front and rear fasciae, Aluminum-optic mirror housings and thundering quad exhaust outlets all add to the plot. Then performance takes the lead, thanks to the combination of a powerful TFSI® engine and dynamic suspension.

3.0-liter supercharged TFSI® V6 engine
333 horsepower
0-60 mph in 4.9 seconds
Top track speed of 155 mph^{1,2}

S4



2015 Audi S4 shown in Misano Red pearl.



2015 Audi S4 shown in Misano Red pearl with available equipment.



1. Top track speed is electronically limited in the U.S. Always obey all speed and traffic laws.
2. Top track speed is limited to 130 mph when equipped with all-season tires.



Model 001
S4

S4

The climax of any Audi S4 story comes from the power produced by the supercharged 3.0-liter TFSI® V6 engine, which pumps out 333 hp and delivers an impressive 325 lb-ft of torque. With the option of a six-speed manual or a seven-speed S tronic® dual-clutch transmission, you can serve up the performance any way you like it—and that's a line worthy of any well-told story.

2015 Audi S4 shown with Black/Magma Red leather and available equipment.

- ENGINE // 3.0-liter supercharged TFSI® V6 engine developing 333 hp and 325 lb-ft of torque with S quad exhaust outlets
- DRIVETRAIN // quattro® all-wheel drive, available sport differential, six-speed manual transmission or an available seven-speed S tronic® dual-clutch transmission
- CHASSIS // S4 tuned sport suspension, Audi drive select and available dynamic steering
- BRAKES // 13.6" ventilated front disc brakes with S4 logo, 13.0" ventilated rear disc brakes
- PERFORMANCE // Top track speed of 155 mph,^{1,2} acceleration 0–60 mph in 4.9 seconds



1 Top track speed is electronically limited in the U.S. Always obey all speed and traffic laws. 2 Top track speed is limited to 130 mph when equipped with all-season tires.

The Audi S3 Sedan proves there's nothing wrong with all play and no work. Uncompromised from the first burst of acceleration, the all-new Audi S3 Sedan may be a bit smaller in stature, but it's never short on power. With 292 hp, quattro® all-wheel-drive performance and available Audi magnetic ride suspension, this is a precision rocket of a sports car. Progressive steering delivers the premium precision you'd expect, while the overall dynamics—the kind built to track specs—get every ounce of performance potential out of the engine without breaking a sweat. The S3 Sedan is a city car and a highway gem. It expresses the kind of power that never has to work hard to play.

2.0-liter turbocharged TFSI® four-cylinder engine
292 horsepower
0-60 mph in 4.7 seconds
Top track speed of 155 mph¹

S3



2015 Audi S3 Sedan shown in Misano Red pearl with available equipment.

¹ Top track speed is electronically limited in the U.S. Always obey all speed and traffic laws.



2015 Audi S3 Sedan shown with Black Fine Nappa leather and available equipment.



S3

There's never a doubt about its heritage. The interior of the Audi S3 Sedan is unmistakably all Audi performance. From the pronounced seat side bolsters to available Fine Nappa leather with contrasting diamond-stitched shoulder bolsters, the sport seat announces the uncompromised luxury and premium materials found throughout the S3 Sedan. The fit and finish lives up to our legendary standards, of course, and flourishes abound; like the race-inspired three-spoke multifunction flat-bottom sport steering wheel with shift paddles or the exceptional quality of the Aluminum-optic pedal clusters and footrest. Nothing inside the S3 Sedan is a small gesture, rather it's a big statement on just how accommodating Audi craftsmanship can be.

ENGINE // 2.0-liter turbocharged TFSI® four-cylinder engine developing 292 hp and 280 lb-ft of torque with S quad exhaust outlets

DRIVETRAIN // quattro® all-wheel drive with six-speed S tronic® dual-clutch transmission

CHASSIS // S3 tuned sport suspension or available Audi magnetic ride, Audi drive select

BRAKES // 13.4" ventilated front disc brakes with S3 logo, 12.2" ventilated rear disc brakes

PERFORMANCE // Top track speed of 155 mph¹; acceleration 0-60 mph in 4.7 seconds

¹ Top track speed is electronically limited in the U.S. Always obey all speed and traffic laws.



The Audi TTS stands apart. Its commitment to progressive performance is felt in every stitch and every corner—yet the TTS delivers even more. Style, for starters. The more aggressive lines of the TTS speak of power—and its brilliant design showcases the passion that its performance inspires. Meanwhile, the nimble TTS delivers dynamic driving through lightweight materials and a responsive throttle. In all, the balance, style and power make for a vehicle that stands out in a standout Audi performance lineup.

TTS

/ TTS COUPE / TTS ROADSTER /



2015 Audi TTS Roadster shown in Ibis White.

2.0-liter turbocharged TFSI® four-cylinder engine
265 horsepower
0–60 mph in 4.9 to 5.1 seconds
Top track speed of 155 mph¹

P/066-067

TTS



2015 Audi TTS Coupe shown in Misano Red pearl.



¹ Top track speed is electronically limited in the U.S. Always obey all speed and traffic laws.



TTS

/ TTS COUPE / TTS ROADSTER /

The power is articulated by a 265-hp 2.0-liter TFSI® engine and transferred to the road through a rapid-shifting S tronic® dual-clutch transmission, taking full advantage of the streamlined weight and shape of the TTS. And thanks to the ultra® lightweight technology-inspired ASF® aluminum construction, specially tuned Audi magnetic ride suspension and quattro® all-wheel drive, your TTS is ultrasensitive and nimble. Put it all together and you have a high-tech performance machine that lets you drive your TTS the way it was meant to be driven.¹



2015 Audi TTS Roadster shown with Black/Magma Red leather and available equipment.

- ENGINE // 2.0-liter turbocharged TFSI® four-cylinder engine developing 265 hp and 258 lb-ft of torque with S quad exhaust outlets
- DRIVETRAIN // quattro® all-wheel drive, six-speed S tronic® dual-clutch transmission
- CHASSIS // TTS tuned sport suspension, Audi magnetic ride
- BRAKES // 13.4" ventilated front disc brakes with TTS logo, 12.2" ventilated rear disc brakes
- PERFORMANCE // Top track speed of 155 mph,² acceleration 0-60 mph in 4.9 seconds (Coupe) and 5.1 seconds (Roadster)

¹ Always obey all speed and traffic laws. ² Top track speed is electronically limited in the U.S. Always obey all speed and traffic laws.

It's a riveting, powerfully rendered solution to a long-standing conundrum about finding the perfect SUV. It used to be, "What is it?" With the Audi SQ5, now we know. It's everything. It is versatile in performance and handling, with quattro® all-wheel drive making its presence felt. It is crisply stylish, an SUV smartly streamlined by signature design lines and a wide stance. But it is also sculpted muscle and luxury refinement. It has the numbers, it wears its available Fine Nappa leather well. It is an Audi SUV literally shaped and imbued with Audi power. The SQ5 is the stunning everything in elevated performance.

SQ5



2015 Audi SQ5 shown in Mythos Black metallic with available equipment.

3.0-liter supercharged TFSI® V6 engine
354 horsepower
0-60 mph in 5.1 seconds
Top track speed of 155 mph¹

8/679-677
SQ5

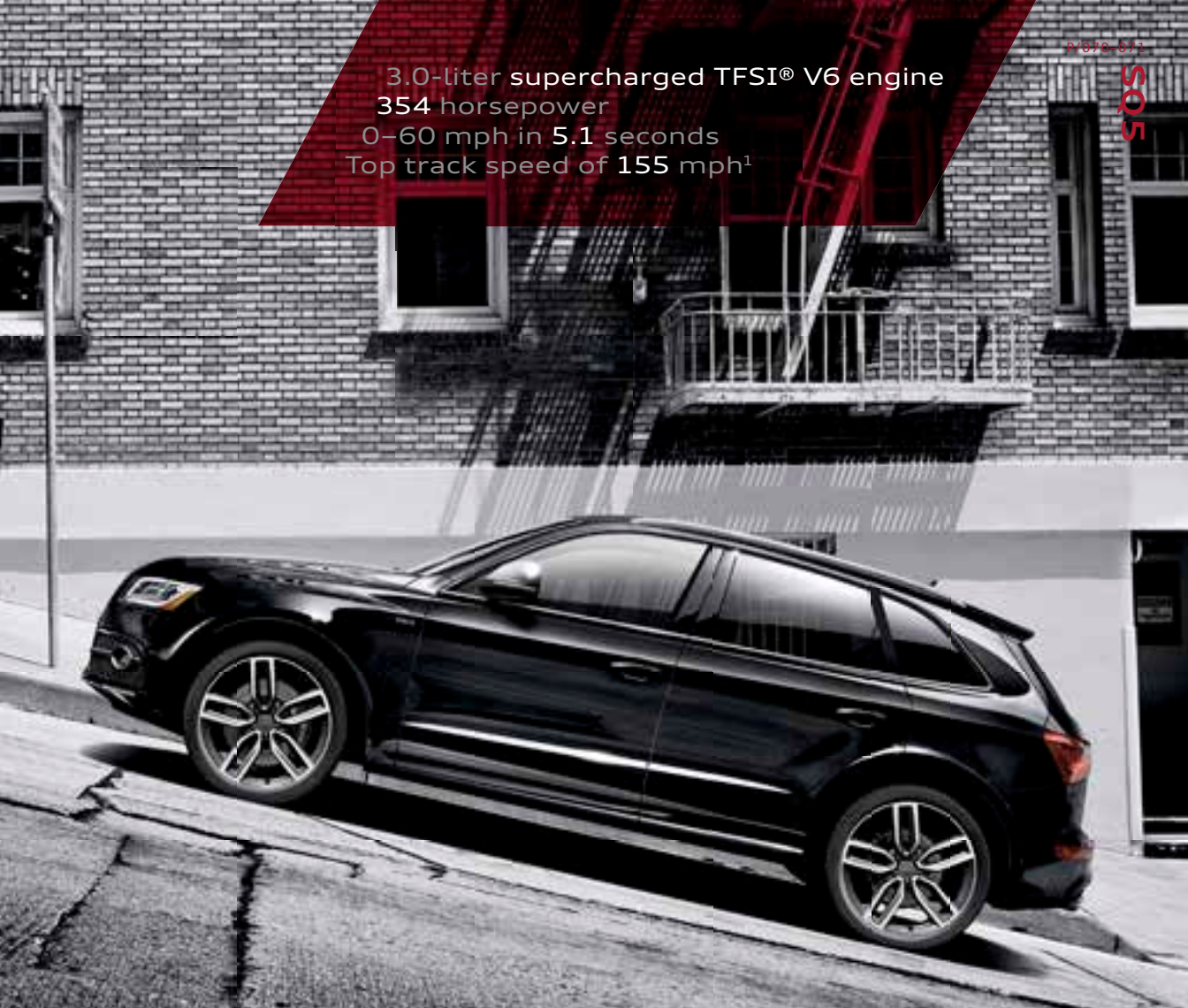

¹ Top track speed is electronically limited in the U.S. Always obey all speed and traffic laws.



SQ5

Imagine an interior so exquisite that its only possible counterpart could be the bold lines and aggressive stance of the Audi SQ5. An interior that never lets you forget you're driving one of the most exhilarating SUVs on the road, while doing so with a level of class that can only be described as trademark Audi quality. Available Fine Nappa leather front seats, finely crafted aluminum-layered Black Wood inlays surround you for just the right amount of flair, and voluminous cargo space, made even more capable by a 40/20/40-split rear seat, means far-flung family excursions are never out of the question.

2015 Audi SQ5 shown with Black/Lunar Silver leather and available equipment.

ENGINE // 3.0-liter supercharged TFSI® V6 engine developing 354 hp and 346 lb-ft of torque with S quad exhaust outlets

DRIVETRAIN // quattro® all-wheel drive, eight-speed Tiptronic® automatic transmission

CHASSIS // SQ5 tuned sport suspension, Audi drive select and available dynamic steering

BRAKES // 15.0" ventilated front disc brakes with SQ5 logo, 13.0" ventilated rear disc brakes

PERFORMANCE // Top track speed of 155 mph¹; acceleration 0-60 mph in 5.1 seconds

¹ Top track speed is electronically limited in the U.S. Always obey all speed and traffic laws.



S line®



sport seats

S line Competition package exclusive aluminum manual shift knob



sport bumper

alloy wheels

side sills

Audi A5 Coupe shown with S line Competition package

Sometimes, the lines themselves carry the performance. 

With the available S line, we give Audi Sport® style to a conventionally stunning Audi vehicle. So with select Audi models, you can get the more aggressive lines—and double takes—that come with Audi Sport design. More striking lines define the exterior, while inside we deliver high-end flourishes, like distinctive decorative inlays throughout—the glint of which might just match the gleam in your eye. All in all, it's safe to say these premium features and packages are a sporty take on tradition.

Gloss Black window trims and side mirror housings



S line door sill inlays



Flat-bottom three-spoke multifunction sport steering wheel



Piano Black decorative inlays

Audi exclusive

There's more than one reason your fingerprints are all over it.

Individuality is good. Unique takes it to the next level. It's when you claim something as totally yours. An original, something you've commissioned that expresses your cultivated tastes or sensibility. Audi exclusive. As much your work as ours, it is a premium service for a most premium vehicle, allowing you to put your personal touch on the paint color of your Audi, or the type of leather, or the type of custom decorative inlay—or all of them. Enjoy the luxury of self-expression with a program that is as unique as your fingerprint, and materials that were crafted to touch.



Audi exclusive paint

It's possible with Audi exclusive. If you can find the hue, we can apply it, to create your custom expressive luxury masterpiece. A spectrum of choices that help capture the color that moves you most.



Audi exclusive leather

Specify your seats, then your particular style of leather, its color and even the color of the stitching you'd like to grace your seating surfaces. Use our exclusive choices of leather grains and colors to contrast with the exterior, or complement it.



Audi exclusive inlays

The ultimate application of fit and finish, exclusive inlays come from woods and metals that complement the stature and design of your interior. Crafted from the finest cuts, our wood inlays add depth of character, while metals add a luster that underlines what exclusive really means.

R8 V10 plus Specifications and Featured Content

R8 V10 plus engineering/performance

5.2-liter FSI® V10
550 hp @ 8,000 rpm 398 lb-ft torque @ 6,500 rpm
0-60 mph in 3.3-3.7 sec/Top track speed of 197-198 mph ¹

R8 V10 plus featured highlights

ultra® lightweight technology—ASF® aluminum construction
Six-speed manual transmission
R8 V10 plus sport suspension calibration
quattro® all-wheel drive
19" 5-double-spoke Y design wheels (Titanium finish)
235/35 front and 295/30 rear summer performance tires ²
Audi ceramic brakes
Audi hill hold assist
Singleframe® grille
Full LED headlights
LED taillights
Carbon Sigma front spoiler lip
Carbon Sigma exterior side mirror housings
Carbon Sigma Audi sideblades
Auto-dimming interior rear view mirror with digital compass
Adaptive rear spoiler
Carbon Sigma diffuser
R8 model round exhaust with Black outlets
R8 V10 plus model exterior appearance
Carbon Sigma engine compartment inlays
Automatic climate control
Three-spoke multifunction flat-bottom sport steering wheel
Tilt and telescopic manually adjustable steering column
Carbon Sigma decorative inlays
Carbon Sigma door sill inlays
Alcantara® headliner
Leather/Alcantara® seating surfaces
Extended Leather package (Includes leather-wrapped center console, knee pads, parking brake, radio surround, lower door trims and passenger's side pull handle)
Heated six-way manually adjustable front sport seats, including four-way power lumbar adjustment
Audi navigation plus with traffic information ³
Driver information system with lap timer
Audi concert radio with seven speakers, six-disc CD changer and MP3 playback capability
SiriusXM® Satellite Radio with 90-day trial subscription ³

R8 V10 plus featured highlights (continued)

BLUETOOTH® wireless technology preparation for mobile phone with safety belt microphones ⁴
Cruise control with coast, resume and accelerate features
Parking system plus with rear view camera (front and rear acoustic parking sensors)

R8 V10 plus stand-alone options

Seven-speed S tronic® dual-clutch transmission with steering wheel-mounted shift paddles
19" 5-double-spoke Y design wheels (Silver finish) with 235/35 front and 295/30 rear summer performance tires ²
Sport exhaust system with Black outlets (S tronic® dual-clutch transmission required)
Fine Nappa leather with contrast stitching
Bang & Olufsen® Sound System with 12 speakers and 465 watts
Audi music interface with iPod® integration (without six-disc CD changer)
Aluminum Race decorative inlays

R8 V10 plus available packages

Fine Nappa Leather package

- ▶ Fine Nappa leather seats and door armrests
- ▶ Eight-way power front sport seats

Full Fine Nappa Leather package

- ▶ Fine Nappa leather seats and door armrests
- ▶ Eight-way power front sport seats
- ▶ Full Leather package (Includes leather-wrapped contents from the Extended Leather package and adds dashboard, monoposto, door shoulders and rear side trims)

Diamond Stitch Full Leather package

- ▶ Fine Nappa leather seats with contrast diamond stitching
- ▶ Eight-way power front sport seats
- ▶ Contrast diamond stitched interior components
- ▶ Alcantara® headliner with diamond stitching
- ▶ Full Leather package (Includes leather-wrapped contents from the Extended Leather package and adds dashboard, monoposto, door shoulders and rear side trims)

R8 V10 Specifications and Featured Content

R8 V10 engineering/performance

5.2-liter FSI® V10

525 hp @ 8,000 rpm

391 lb-ft torque @ 6,500 rpm

0–60 mph in 3.4–4.0 sec/Top track speed of 193–196 mph¹

R8 V10 featured highlights

ultra® lightweight technology—ASF® aluminum construction

Six-speed manual transmission

R8 V10 tuned Audi magnetic ride

quattro® all-wheel drive

19" 10-spoke Y design wheels (Polished/Titanium finish)

235/35 front and 295/30 rear summer performance tires²

14.4" ventilated wave-design front and 14.0" ventilated wave-design rear disc brakes

Audi hill hold assist

Singleframe® grille

Full LED headlights

LED taillights

Power-folding exterior side mirrors

Auto-dimming interior rear view mirror with digital compass

Adaptive rear spoiler

R8 model round exhaust outlets

R8 V10 model exterior appearance

Carbon Sigma engine compartment inlays

Aluminum-optic engine vent covers (Spyder)

Automatic climate control

Three-spoke multifunction flat-bottom sport steering wheel

Tilt and telescopic manually adjustable steering column

Black Silk Matte decorative inlays

Alcantara® headliner (Coupe)

Fine Nappa leather seats and door armrests

Extended Leather package (Includes leather-wrapped center console, knee pads, parking brake, radio surround, lower door trims and passenger's side pull handle)

Heated twelve-way power front sport seats, including four-way power lumbar adjustment

Audi navigation plus with traffic information³

Driver information system with lap timer

Bang & Olufsen® Sound System with 12 speakers and 465 watts

SiriusXM® Satellite Radio with 90-day trial subscription³

BLUETOOTH® wireless technology preparation for mobile phone with safety belt microphones⁴

Cruise control with coast, resume and accelerate features

Parking system plus with rear view camera (front and rear acoustic parking sensors)

R8 V10 stand-alone options

Seven-speed S tronic® dual-clutch transmission with steering wheel-mounted shift paddles

19" 5-double-spoke design wheels (Polished finish) with 235/35 front and 305/30 rear summer performance tires²

19" 10-spoke Y design wheels (Polished finish) with 235/35 front and 305/30 rear summer performance tires²

Red Brake package

Audi ceramic brakes

Carbon Sigma Audi sideblades (Coupe)

Sport exhaust system with Black outlets (S tronic® dual-clutch transmission required)

Fine Nappa leather with contrast stitching

Full Leather package (Includes leather-wrapped contents from the Extended Leather package and adds dashboard, monoposto, door shoulders and rear side trims)

Carbon Sigma decorative inlays

Piano Black decorative inlays

Aluminum door sill inlays with illumination

Audi music interface with iPod® integration (without six-disc CD changer)

R8 V10 available packages

Full Fine Nappa Leather package

► Fine Nappa leather seats and door armrests

► Full Leather package (Includes leather-wrapped contents from the Extended Leather package and adds dashboard, monoposto, door shoulders and rear side trims)

Diamond Stitch Full Leather package

► Fine Nappa leather seats with contrast diamond stitching

► Contrast diamond stitched interior components

► Alcantara® headliner with diamond stitching (Coupe)

► Full Leather package (Includes leather-wrapped contents from the Extended Leather package and adds dashboard, monoposto, door shoulders and rear side trims)

Audi exclusive Black Optic package

► 19" 5-double-spoke design wheels (Titanium finish) with 235/35 front and 305/30 rear summer performance tires²

► Gloss Black Singleframe® grille

► Gloss Black engine vent covers (Spyder)

► R8 model round exhaust with Black outlets

R8 V8 Specifications and Featured Content

R8 V8 engineering/performance

4.2-liter FSI® V8

430 hp @ 7,900 rpm

317 lb-ft torque @ 4,500–6,000 rpm

0–60 mph in 4.2–4.6 sec/Top track speed of 186–188 mph¹

R8 V8 featured highlights

ultra® lightweight technology—ASF® aluminum construction

Six-speed manual transmission

R8 V8 tuned Audi magnetic ride

quattro® all-wheel drive

19" 5-double-spoke design wheels (Silver finish)

235/35 front and 295/30 rear summer performance tires²

14.4" ventilated wave-design front and 14.0" ventilated wave-design rear disc brakes

Audi hill hold assist

Singleframe® grille

Full LED headlights

LED taillights

Power-folding exterior side mirrors

Auto-dimming interior rear view mirror with digital compass

Adaptive rear spoiler

R8 model round exhaust outlets

R8 V8 model exterior appearance

Aluminum-optic engine vent covers (Spyder)

Automatic climate control

Three-spoke multifunction flat-bottom sport steering wheel

Tilt and telescopic manually adjustable steering column

Black Silk Matte decorative inlays

Black cloth headliner

Leather/Alcantara® seating surfaces

Heated twelve-way power front sport seats, including four-way power lumbar adjustment

Driver information system with lap timer

Audi concert radio with seven speakers, six-disc CD changer and MP3 playback capability

SiriusXM® Satellite Radio with 90-day trial subscription³

BLUETOOTH® wireless technology preparation for mobile phone with safety belt microphones⁴

Cruise control with coast, resume and accelerate features

R8 V8 stand-alone options

Seven-speed S tronic® dual-clutch transmission with steering wheel-mounted shift paddles

19" 5-double-spoke design wheels (Polished finish) with 235/35 front and 305/30 rear summer performance tires²

Red Brake package

Audi ceramic brakes

Carbon Sigma Audi sideblades (Coupe)

Carbon Sigma engine compartment inlays

Alcantara® headliner (Coupe)

Fine Nappa leather with contrast stitching

Carbon Sigma decorative inlays

Piano Black decorative inlays

Aluminum door sill inlays with illumination

Audi navigation plus with traffic information³

Bang & Olufsen® Sound System with 12 speakers and 465 watts

Audi music interface with iPod® integration (without six-disc CD changer)

Parking system plus with rear view camera (front and rear acoustic parking sensors)

R8 V8 available packages

Fine Nappa Leather package

► Fine Nappa leather seats and door armrests

► Extended Leather package (Includes leather-wrapped center console, knee pads, parking brake, radio surround, lower door trims and passenger's side pull handle)

Full Fine Nappa Leather package

► Fine Nappa leather seats and door armrests

► Full Leather package (Includes leather-wrapped contents from the Extended Leather package and adds dashboard, monoposto, door shoulders and rear side trims)

Diamond Stitch Full Leather package

► Fine Nappa leather seats with contrast diamond stitching

► Contrast diamond-stitched interior components

► Alcantara® headliner with diamond stitching (Coupe)

► Full Leather package (Includes leather-wrapped contents from the Extended Leather package and adds dashboard, monoposto, door shoulders and rear side trims)

Audi exclusive Black Optic package

► 19" 5-double-spoke design wheels (Titanium finish) with 235/35 front and 305/30 rear summer performance tires²

► Gloss Black Singleframe® grille

► Gloss Black engine vent covers (Spyder)

► R8 model round exhaust with Black outlets

RS 7 Specifications and Featured Content

RS 7 engineering/performance

4.0-liter turbocharged TFSI® V8 with cylinder on demand™ engine efficiency technology¹

560 hp @ 5,700–6,600 rpm
516 lb-ft torque @ 1,750–5,500 rpm

0–60 mph in 3.7 sec/Top track speed of 174 mph²

RS 7 featured highlights

ultra® lightweight technology—aluminum exterior body panels and a steel chassis

Eight-speed Tiptronic® automatic transmission with steering wheel-mounted shift paddles

RS 7 tuned Audi adaptive air suspension

quattro® all-wheel drive with sport differential

20" 7-twin-spoke RS design wheels (Silver finish)

275/35 summer performance tires³

15.4" ventilated wave-design front and 14.0" ventilated wave-design rear disc brakes

Full LED headlights

LED taillights and rear fog lights

Power tailgate

Adaptive rear spoiler

RS model oval exhaust outlets

RS model exterior appearance (RS exclusive Singleframe® grille, unique front/rear fasciae and side sills, and matte aluminum exterior side mirror housings and window trim)

Four-zone automatic climate control

Three-spoke multifunction sport steering wheel

RS design Carbon Fiber decorative inlays

Black cloth headliner

Sunroof

Valcona leather seats with contrast honeycomb stitching

Heated twelve-way power front sport-contoured seats, including four-way power lumbar adjustment

Split-folding 60/40 rear seatbacks

MMI® navigation plus with voice control system⁴

MMI® touch with handwriting-recognition technology

Audi connect® with six-month trial subscription⁵

7" color driver information system

BOSE® Surround Sound System with 14 speakers, AudioPilot® noise compensation and 630 watts

HD Radio™ Technology

SiriusXM® Satellite Radio with 90-day trial subscription⁴

SiriusXM® Traffic with four-year subscription⁴

Audi music interface with iPod® integration

BLUETOOTH® wireless technology preparation for mobile phone⁶

BLUETOOTH® streaming audio⁶

Audi advanced key—keyless start, stop and entry⁷

Audi side assist and Audi pre sense® rear

Head-up display with navigation information

Audi drive select

Parking system plus with rear view camera (front and rear acoustic parking sensors)

RS 7 stand-alone options

21" 5-spoke-blade design wheels (Silver finish) with 275/30 summer performance tires³

21" 5-spoke-blade design wheels (Titanium finish) with 275/30 summer performance tires³

21" 5-spoke-blade design wheels (Black finish) with 275/30 summer performance tires³

Rear-passenger thorax side airbags⁸

Power soft-closing doors

Sport exhaust system with Black outlets

Black Alcantara® headliner

Layered Aluminum/Black Wood decorative inlays

Aluminum Race decorative inlays

Bang & Olufsen® Advanced Sound System with 15 speakers and 1,300 watts

Night vision assistant with pedestrian detection

RS 7 available packages

Cold Weather package

- ▶ Heated steering wheel (without perforation and RS 7 logo)
- ▶ Heated rear seats
- ▶ A7 style shift knob

Driver Assistance package

- ▶ Audi adaptive cruise control with stop & go
- ▶ Audi active lane assist
- ▶ Audi pre sense plus®
- ▶ Corner view camera system

Individual Contour Seating package

- ▶ Valcona leather seats (without contrast honeycomb stitching)
- ▶ Heated and ventilated 18-way power front comfort seats including four-way power lumbar adjustment and massage function
- ▶ Front passenger seat memory

Dynamic package

- ▶ DRC® suspension system (replaces Audi adaptive air suspension)
- ▶ Dynamic steering
- ▶ Red brake calipers
- ▶ Sport exhaust system with Black outlets

Matte Aluminum Optic package

- ▶ Matte Aluminum-optic front spoiler, lower air intakes and rear diffuser
- ▶ Available with or without Singleframe® grille “quattro” script

Carbon Optic package

- ▶ Carbon fiber front spoiler and rear diffuser
- ▶ Body-colored exterior side mirror housings
- ▶ Gloss Black Singleframe® grille and trim around exterior windows
- ▶ Available with or without Singleframe® grille “quattro” script

Extended Carbon package

- ▶ Engine cover with carbon fiber inserts
- ▶ Carbon fiber exterior side mirror housings

RS 5 Specifications and Featured Content

RS 5 engineering/performance

4.2-liter FSI® V8

450 hp @ 8,250 rpm
317 lb-ft torque @ 4,000–6,000 rpm

0–60 mph in 4.5–4.9 sec/Top track speed of 174 mph²

RS 5 featured highlights

Seven-speed S tronic® dual-clutch transmission with steering wheel-mounted shift paddles

RS 5 sport suspension calibration

quattro® all-wheel drive with sport differential

19" 10-spoke RS design wheels (Silver finish)

265/35 summer performance tires³

14.4" ventilated wave-design front and 12.8" ventilated wave-design rear disc brakes

Adaptive xenon plus headlights with LED daytime running lights

Automatic headlights

LED taillights and rear fog lights

Adaptive rear spoiler (Coupe)

Trunk-mounted rear lip spoiler (Cabriolet)

RS model oval exhaust outlets

RS model exterior appearance (RS exclusive Singleframe® grille, front and rear fasciae, wide-body design, matte aluminum exterior side mirror housings and body-colored door sill blades)

Three-zone automatic climate control

Three-spoke multifunction flat-bottom sport steering wheel

Tilt and telescopic manually adjustable steering column

RS design Carbon Fiber decorative inlays

Black cloth headliner

Panoramic tilting sunroof (Coupe)

Acoustic folding roof—folds at speeds up to 31 mph (Cabriolet)

Fine Nappa leather seats and door armrests

Heated twelve-way power front sport-contoured seats, including four-way power lumbar adjustment

Driver seat memory

Split-folding rear seatbacks

Color driver information system

Bang & Olufsen® Sound System with 14 speakers and 505 watts (Coupe) or 12 speakers and 505 watts (Cabriolet)

SiriusXM® Satellite Radio with 90-day trial subscription⁴

Audi music interface with iPod® integration

BLUETOOTH® wireless technology preparation for mobile phone⁶

Audi advanced key—keyless start, stop and entry⁷

Audi drive select

Parking system plus with front and rear acoustic parking sensors

RS 5 stand-alone options

20" 5-arm-rotor design wheels (Matte Black finish) with 275/30 summer performance tires³

20" 5-arm-rotor design wheels (Matte Black finish and Red surround) with 275/30 summer performance tires³

20" 5-arm-rotor design wheels (Titanium finish) with 275/30 summer performance tires³

20" 5-arm-rotor design wheels (Silver finish) with 275/30 summer performance tires³

Red Brake package

Audi ceramic front brakes

Matte Aluminum Optic package

Sport exhaust system with Black outlets

Aluminum Race decorative inlays

Leather/Alcantara® seating surfaces (Coupe)

RS 5 available packages

Technology package

- ▶ MMI® navigation plus with voice control (voice control not available on Cabriolet)⁴
- ▶ Audi connect® with six-month trial subscription⁵
- ▶ SiriusXM® Traffic with four-year subscription⁴
- ▶ BLUETOOTH® streaming audio⁶
- ▶ Audi side assist
- ▶ Parking system plus with rear view camera (front and rear acoustic parking sensors)

Driver Assistance package

- ▶ Dynamic steering
- ▶ Audi adaptive cruise control

Comfort package

- ▶ Perforated Milano leather seats
- ▶ Ventilated front comfort seats
- ▶ Head-level heating system (Cabriolet)

Black Optic plus package

- ▶ 20" 5-V-spoke design wheels (Titanium finish) with 275/30 summer performance tires³
- ▶ Carbon fiber engine cover
- ▶ Gloss Black Singleframe® grille
- ▶ Matte Black trim around exterior side windows (Coupe)
- ▶ Body-colored exterior side mirror housings
- ▶ Carbon fiber trunk-mounted rear lip spoiler (Cabriolet)
- ▶ Sport exhaust system with Black outlets

¹ 16 city/27 highway/19 combined mpg (2015 Audi RS 7 4.0T with eight-speed Tiptronic® automatic transmission and quattro® all-wheel drive). EPA estimates. Your mileage will vary and depends on several factors, including your driving habits and vehicle condition. ² Top track speed is electronically limited in the U.S. Always obey all speed and traffic laws. ³ See wheels page for important information regarding summer performance and low aspect ratio tires. ⁴ See back cover for important information regarding MMI® navigation plus and required SiriusXM® subscriptions. ⁵ Always pay careful attention to the road, and do not drive while distracted. The features and technologies discussed above are optional, may require an additional subscription with separate terms and conditions, and should be used only when it is safe and appropriate. The Wi-Fi® hotspot feature is intended for passenger use only. ⁶ Requires compatible device. ⁷ Some Audi models are equipped with a keyless ignition feature. The details as to how the system works can vary, and Audi owners should consult their owner's literature or an authorized Audi dealer if they have further questions about the operation of this feature. Please note that Audi warns against leaving the vehicle unattended with the engine running, particularly in enclosed spaces. ⁸ Airbags are supplemental restraints only and will not deploy in all crash circumstances. Always use safety belts and seat children only in the rear, using restraint systems appropriate for their size and age.

S8 Specifications and Featured Content

S8 engineering/performance

4.0-liter turbocharged TFSI® V8 with cylinder on demand™ engine efficiency technology¹

520 hp @ 5,800 rpm
481 lb-ft torque @ 1,700 rpm

0–60 mph in 3.9 sec/Top track speed of 155 mph²

S8 featured highlights

ultra® lightweight technology—ASF® aluminum construction

Eight-speed Tiptronic® automatic transmission with steering wheel-mounted shift paddles

S8 tuned Audi adaptive air suspension

quattro® all-wheel drive with sport differential

Dynamic steering

21" 5-triple-spoke design wheels (Silver finish)

265/35 summer performance tires³

15.7" ventilated front and 14.0" ventilated rear disc brakes

Full LED headlights

LED taillights and rear fog lights

Power soft-closing doors

Power trunk with hands-free release

S model quad exhaust outlets

S model exterior appearance (Platinum Gray Singleframe® grille, unique front/rear fasciae and side sills, Aluminum-optic front/rear twin-blade fins and exterior side mirror housings)

Four-zone automatic climate control

Three-spoke multifunction sport steering wheel

Power tilt and telescopic adjustable steering column

Carbon Atlas decorative upper inlays and shifter lever

Matte Brushed Aluminum decorative lower inlays

Power rear side and rear window sunshades

Alcantara® headliner

Sunroof

Valcona leather seats with diamond quilting

Heated and ventilated 22-way power front sport comfort seats, including four-way power lumbar adjustment and massage function

Driver and front passenger seat memory

MMI® navigation plus with voice control⁴

MMI® touch with handwriting-recognition technology

Audi connect® with six-month trial subscription⁵

7" color driver information system

BOSE® Surround Sound System with 14 speakers, AudioPilot® noise compensation and 630 watts

HD Radio™ Technology

SiriusXM® Satellite Radio with 90-day trial subscription⁴

SiriusXM® Traffic with four-year subscription⁴

Audi music interface with iPod® integration

BLUETOOTH® wireless technology preparation for mobile phone⁶

BLUETOOTH® streaming audio⁶

Audi advanced key—keyless start, stop and entry⁷

S8 featured highlights (continued)

Audi side assist and Audi pre sense® rear

Head-up display with navigation information

Audi drive select

Parking system plus with rear view camera (front and rear acoustic parking sensors)

Top and corner view camera system

S8 stand-alone options

21" 5-arm-rotor design wheels (Titanium finish) with 275/35 summer performance tires³

21" 5-arm-rotor design wheels (Silver finish) with 275/35 summer performance tires³

Full Leather package

Leather-wrapped shifter lever

Black Alcantara® headliner

Solar sunroof

Assam Gray Vavona Wood decorative upper inlays

Brown/Silver Poplar Wood decorative upper inlays

Dark Brown Walnut Wood decorative upper inlays

Velvet Brown Fine Grain Ash Wood decorative upper inlays

Bang & Olufsen® Advanced Sound System with 19 speakers and 1,400 watts

Rear Seat Entertainment with dual 10" screens and single DVD player

Night vision assistant with pedestrian detection

S8 available packages

Cold Weather package

▶ Heated steering wheel

▶ Heated rear seats

▶ Rear-seat pass-through

Driver Assistance package

▶ Audi adaptive cruise control with stop & go

▶ Audi active lane assist

▶ Audi pre sense® plus

Audi design selection, Balao Brown

▶ Balao Brown Valcona leather seats, trim and shifter

▶ Comfort front seats (without diamond quilting)

▶ Balsamic Brown Natural Fine Grain Ash Wood decorative upper inlays

▶ Full Leather package

▶ White Alcantara® headliner, stitching and seat piping

Audi design selection, Vermont Brown

▶ Vermont Brown Valcona leather seats with diamond quilting

▶ Carbon Copper Twill decorative upper inlays

▶ Piano Black shifter lever

▶ Full Leather package

▶ Granite Gray stitching and seat piping

S7 Specifications and Featured Content

S7 engineering/performance

4.0-liter turbocharged TFSI® V8 with cylinder on demand™ engine efficiency technology⁸

420 hp @ 5,500–6,400 rpm
406 lb-ft torque @ 1,400–5,200 rpm

0–60 mph in 4.5 sec/Top track speed of 155 mph²

S7 featured highlights

ultra® lightweight technology—aluminum exterior body panels and a steel chassis

Seven-speed S tronic® dual-clutch transmission with steering wheel-mounted shift paddles

S7 tuned Audi adaptive air suspension

quattro® all-wheel drive with sport differential

19" 5-parallel-spoke S design wheels (Silver finish)

255/40 summer performance tires³

15.7" ventilated front and 14.0" ventilated rear disc brakes

Full LED headlights

LED taillights and rear fog lights

Power tailgate

Adaptive rear spoiler

S model quad exhaust outlets

S model exterior appearance (Platinum Gray Singleframe® grille, unique front/rear fasciae and side sills, Aluminum-optic front/rear twin-blade fins and exterior side mirror housings)

Four-zone automatic climate control

Three-spoke multifunction sport steering wheel

Power tilt and telescopic adjustable steering column

Fine Grain Ash Natural Brown Wood decorative inlays

Sunroof

Valcona leather seats with contrast diamond stitching

Heated twelve-way power front sport-contoured seats, including four-way power lumbar adjustment

Driver seat memory

Split-folding 60/40 rear seatbacks

MMI® navigation plus with voice control system⁴

MMI® touch with handwriting-recognition technology

Audi connect® with six-month trial subscription⁵

7" color driver information system

BOSE® Surround Sound System with 14 speakers, AudioPilot® noise compensation and 630 watts

HD Radio™ Technology

SiriusXM® Satellite Radio with 90-day trial subscription⁴

SiriusXM® Traffic with four-year subscription⁴

Audi music interface with iPod® integration

BLUETOOTH® wireless technology preparation for mobile phone⁶

S7 featured highlights (continued)

BLUETOOTH® streaming audio⁶

Audi advanced key—keyless start, stop and entry⁷

Audi side assist and Audi pre sense® rear

Head-up display with navigation information

Audi drive select

Parking system plus with rear view camera (front and rear acoustic parking sensors)

S7 stand-alone options

20" 5-parallel-spoke S design wheels (Silver finish) with 265/35 summer performance tires³

Rear-passenger thorax side airbags⁹

Power soft-closing doors

Black cloth headliner

Black Alcantara® headliner

Carbon Atlas decorative inlays

Layered Aluminum/Black Wood decorative inlays

Matte Brushed Aluminum decorative inlays

Bang & Olufsen® Advanced Sound System with 15 speakers and 1,300 watts

Night vision assistant with pedestrian detection

S7 available packages

Cold Weather package

▶ Heated steering wheel

▶ Heated rear seats

Driver Assistance package

▶ Audi adaptive cruise control with stop & go

▶ Audi active lane assist

▶ Audi pre sense® plus

▶ Corner view camera system

Individual Contour Seating package

▶ Valcona leather seats (without contrast diamond stitching)

▶ Heated and ventilated 18-way power front comfort seats including four-way power lumbar adjustment and massage function

▶ Front passenger seat memory

Black Optic package

▶ 20" 5-double-spoke design wheels (Titanium finish) with 265/35 summer performance tires³

▶ Gloss Black Singleframe® grille

▶ Gloss Black trim around exterior side windows

▶ Body-colored exterior side mirror housings

1. 17 city/27 highway/20 combined mpg (2015 Audi S8 with eight-speed Tiptronic® automatic transmission and quattro® all-wheel drive). EPA estimates. Your mileage will vary and depends on several factors, including your driving habits and vehicle condition. 2. Top track speed is electronically limited in the U.S. Always obey all speed and traffic laws. 3. See wheels page for important information regarding summer performance and low aspect ratio tires. 4. See back cover for important information regarding MMI® navigation plus and required SiriusXM® subscriptions. 5. Always pay careful attention to the road, and do not drive while distracted. The features and technologies discussed above are optional, may require an additional subscription with separate terms and conditions, and should be used only when it is safe and appropriate. The Wi-Fi® hotspot feature is intended for passenger use only. 6. Requires compatible device. 7. Some Audi models are equipped with a keyless ignition feature. The details as to how the system works can vary, and Audi owners should consult their owner's literature or an authorized Audi dealer if they have further questions about the operation of this feature. Please note that Audi warns against leaving the vehicle unattended with the engine running, particularly in enclosed spaces. 8. 17 city/27 highway/20 combined mpg (2015 Audi S7 4.0T with seven-speed S tronic® dual-clutch transmission and quattro® all-wheel drive). EPA estimates. Your mileage will vary and depends on several factors, including your driving habits and vehicle condition. 9. Airbags are supplemental restraints only and will not deploy in all crash circumstances. Always use safety belts and seat children only in the rear, using restraint systems appropriate for their size and age.

S6 Specifications and Featured Content

S6 engineering/performance

4.0-liter turbocharged TFSI® V8 with cylinder on demand™ engine efficiency technology¹

420 hp @ 5,500–6,400 rpm

406 lb-ft torque @ 1,400–5,200 rpm

0–60 mph in 4.5 sec/Top track speed of 155 mph²

S6 featured highlights

ultra® lightweight technology—aluminum exterior body panels and a steel chassis

Seven-speed S tronic® dual-clutch transmission with steering wheel-mounted shift paddles

S6 tuned Audi adaptive air suspension

quattro® all-wheel drive with sport differential

19" 5-parallel-spoke S design wheels (Silver finish)

255/40 summer performance tires³

15.7" ventilated front and 14.0" ventilated rear disc brakes

Full LED headlights

LED taillights and rear fog lights

S model quad exhaust outlets

S model exterior appearance (Platinum Gray Singleframe® grille, unique front/rear fasciae and side sills, Aluminum-optic front/rear twin-blade fins and exterior side mirror housings, and body-colored trunk-mounted rear lip spoiler)

Four-zone automatic climate control

Three-spoke multifunction sport steering wheel

Power tilt and telescopic adjustable steering column

Fine Grain Ash Natural Brown Wood decorative inlays

Manual rear-side window and power rear window sunshades

Sunroof

Valcona leather seats with contrast diamond stitching

Heated twelve-way power front sport-contoured seats, including four-way power lumbar adjustment

Driver seat memory

Split-folding 60/40 rear seatbacks

MMI® navigation plus with voice control system⁴

MMI® touch with handwriting-recognition technology

Audi connect® with six-month trial subscription⁵

7" color driver information system

BOSE® Surround Sound System with 14 speakers, AudioPilot® noise compensation and 630 watts

HD Radio™ Technology

SiriusXM® Satellite Radio with 90-day trial subscription⁴

SiriusXM® Traffic with four-year subscription⁴

Audi music interface with iPod® integration

BLUETOOTH® wireless technology preparation for mobile phone⁶

BLUETOOTH® streaming audio⁵

S6 featured highlights (continued)

Audi advanced key—keyless start, stop and entry⁷

Audi side assist and Audi pre sense® rear

Head-up display with navigation information

Audi drive select

Parking system with rear view camera (front and rear acoustic parking sensors)

S6 stand-alone options

20" 5-parallel-spoke S design wheels (Silver finish) with 255/35 summer performance tires³

Rear-passenger thorax side airbags⁸

Black cloth headliner

Black Alcantara® headliner

Carbon Atlas decorative inlays

Layered Aluminum/Black Wood decorative inlays

Matte Brushed Aluminum decorative inlays

Bang & Olufsen® Advanced Sound System with 15 speakers and 1,300 watts

Night vision assistant with pedestrian detection

S6 available packages

Cold Weather package

▶ Heated steering wheel

▶ Heated rear seats

Driver Assistance package

▶ Audi adaptive cruise control with stop & go

▶ Audi active lane assist

▶ Audi pre sense® plus

▶ Top and corner view camera system

Individual Contour Seating package

▶ Valcona leather seats (without contrast diamond stitching)

▶ Heated and ventilated 18-way power front comfort seats, including four-way power lumbar adjustment and massage function

▶ Front passenger seat memory

Black Optic package

▶ 20" 5-arm-rotor design wheels (Titanium finish) with 255/35 summer performance tires³

▶ Gloss Black Singleframe® grille

▶ Gloss Black trim around exterior side windows

▶ Body-colored exterior side mirror housings

S5 Specifications and Featured Content

S5 engineering/performance

3.0-liter supercharged TFSI® V6

333 hp @ 5,500–6,500 rpm

325 lb-ft torque @ 2,900–5,300 rpm

0–60 mph in 4.9–5.3 sec/Top track speed of 155 mph²

S5 Premium Plus featured highlights

Six-speed manual transmission (Coupe)

Seven-speed S tronic® dual-clutch transmission with steering wheel-mounted shift paddles (Cabriolet)

S5 sport suspension calibration

quattro® all-wheel drive

18" 5-parallel-spoke S design wheels (Silver finish)

245/40 summer performance tires³

13.6" ventilated front and 13.0" ventilated rear disc brakes

Xenon plus headlights with LED daytime running lights

Front fog lights

LED taillights and rear fog lights

S model quad exhaust outlets

S model exterior appearance (Platinum Gray Singleframe® grille, Aluminum-optic front/rear twin blades and exterior side mirror housings, body-colored door sill blades and integrated rear spoiler)

Three-zone automatic climate control

Three-spoke multifunction flat-bottom sport steering wheel

Matte Brushed Aluminum decorative inlays

Black cloth headliner

Panoramic tilting sunroof (Coupe)

Acoustic folding roof—folds at speeds up to 31 mph (Cabriolet)

Leather/Alcantara® seating surfaces (Coupe)

Fine Nappa leather seats and door armrests (Cabriolet)

Heated twelve-way power front sport-contoured seats, including four-way power lumbar adjustment

Driver seat memory

Split-folding rear seatbacks

Color driver information system

Audi concert radio with ten speakers and single CD player with MP3 playback capability

SiriusXM® Satellite Radio with 90-day trial subscription⁴

Audi music interface with iPod® integration

BLUETOOTH® wireless technology preparation for mobile phone⁶

Audi advanced key—keyless start, stop and entry⁷

Audi drive select

S5 Prestige featured highlights (adds to or replaces features from S5 Premium Plus)

Adaptive xenon plus headlights with LED daytime running lights

MMI® navigation plus with voice control (voice control not available on Cabriolet)⁴

Audi connect® with six-month trial subscription⁵

S5 Prestige featured highlights (continued)

Bang & Olufsen® Sound System with 14 speakers and 505 watts (Coupe) or 12 speakers and 505 watts (Cabriolet)

HD Radio™ Technology

SiriusXM® Traffic with four-year subscription⁴

BLUETOOTH® streaming audio⁶

Audi side assist

Parking system with rear view camera

S5 stand-alone options

Seven-speed S tronic® dual-clutch transmission with steering wheel-mounted shift paddles (Coupe)

Adaptive damping suspension

Sport differential

245/40 R18 all-season tires (Coupe, top track speed lowered to 130 mph)^{2,3}

19" 10 Y-spoke design wheels (Silver finish) with 255/35 summer performance tires³

19" 7-double-spoke RS design wheels (Silver finish) with 255/35 summer performance tires³

19" 5-arm-rotor design wheels (Titanium finish) with 255/35 summer performance tires (Cabriolet)³

Carbon Atlas decorative inlays

Layered Aluminum/Black Wood decorative inlays

Fine Nappa leather seats and door armrests (Coupe)

Bang & Olufsen® Sound System (Premium Plus)

S5 available packages

Technology package (Premium Plus)

▶ MMI® navigation plus with voice control (voice control not available on Cabriolet)⁴

▶ Audi connect® with six-month trial subscription⁵

▶ SiriusXM® Traffic with four-year subscription⁴

▶ BLUETOOTH® streaming audio⁶

▶ Audi side assist

▶ Parking system with rear view camera

Driver Assistance package (Prestige)

▶ Dynamic steering

▶ Audi adaptive cruise control

Luxury/Comfort package (Coupe, Prestige/Cabriolet, Premium Plus and Prestige)

▶ Perforated Milano leather seats

▶ Ventilated front comfort seats

▶ Head-level heating system (Cabriolet)

High Gloss Black package (Coupe, Premium Plus and Prestige)

▶ 19" 5-arm-rotor design wheels (Titanium finish) with 255/35 summer performance tires³

▶ Gloss Black Singleframe® grille

▶ Gloss Black trim around exterior side windows

▶ Body-colored exterior side mirror housings

1 17 city/27 highway/20 combined mpg (2015 Audi S6 4.0T with seven-speed S tronic® dual-clutch transmission and quattro® all-wheel drive). EPA estimates. Your mileage will vary and depends on several factors, including your driving habits and vehicle condition. 2 Top track speed is electronically limited in the U.S. Always obey all speed and traffic laws. 3 See wheels page for important information regarding summer performance and low aspect ratio tires. 4 See back cover for important information regarding MMI® navigation plus and required SiriusXM® subscriptions. 5 Always pay careful attention to the road, and do not drive while distracted. The features and technologies discussed above are optional, may require an additional subscription with separate terms and conditions, and should be used only when it is safe and appropriate. The Wi-Fi® hotspot feature is intended for passenger use only. 6 Requires compatible device. 7 Some Audi models are equipped with a keyless ignition feature. The details as to how the system works can vary, and Audi owners should consult their owner's literature or an authorized Audi dealer if they have further questions about the operation of this feature. Please note that Audi warns against leaving the vehicle unattended with the engine running, particularly in enclosed spaces. 8 Airbags are supplemental restraints only and will not deploy in all crash circumstances. Always use safety belts and seat children only in the rear, using restraint systems appropriate for their size and age.

S4 Specifications and Featured Content

S4 engineering/performance

3.0-liter supercharged TFSI® V6

333 hp @ 5,500–6,500 rpm
325 lb-ft torque @ 2,900–5,300 rpm

0–60 mph in 4.9 sec/Top track speed of 155 mph¹

S4 Premium Plus featured highlights

Six-speed manual transmission

S4 sport suspension calibration

quattro® all-wheel drive

18" 5-parallel-spoke S design wheels (Silver finish)

245/40 summer performance tires²

13.6" ventilated front and 13.0" ventilated rear disc brakes

Xenon plus headlights with LED daytime running lights

Automatic headlights

Front fog lights

LED taillights and rear fog lights

S model quad exhaust outlets

S model exterior appearance (Platinum Gray Singleframe® grille, Aluminum-optic front/rear twin blades and exterior side mirror housings, body-colored door sill blades and integrated rear spoiler)

Three-zone automatic climate control

Three-spoke multifunction flat-bottom sport steering wheel

Tilt and telescopic manually adjustable steering column

Matte Brushed Aluminum decorative inlays

Aluminum door sill inlays

Front and rear floor mats

Black cloth headliner

Power windows with one-touch up/down operation and pinch protection

Sunroof

Leather/Alcantara® seating surfaces

Heated twelve-way power front sport-contoured seats, including four-way power lumbar adjustment

Driver seat memory

Split-folding 60/40 rear seatbacks

Driver information system

Audi concert radio with ten speakers and single CD player with MP3 playback capability

SiriusXM® Satellite Radio with 90-day trial subscription³

Audi music interface with iPod® integration

BLUETOOTH® wireless technology preparation for mobile phone⁴

Audi advanced key—keyless start, stop and entry⁵

Audi drive select

S4 Prestige featured highlights (adds to or replaces features from S4 Premium Plus)

Adaptive xenon plus headlights with LED daytime running lights

MMI® navigation plus with voice control³

Audi connect® with six-month trial subscription⁶

Color driver information system

Bang & Olufsen® Sound System with 14 speakers and 505 watts

HD Radio™ Technology

SiriusXM® Traffic with four-year subscription³

BLUETOOTH® streaming audio⁴

Audi side assist

Parking system with rear view camera

S4 stand-alone options

Seven-speed S tronic® dual-clutch transmission with steering wheel-mounted shift paddles

Adaptive damping suspension

Sport differential

245/40 R18 all-season tires (Top track speed lowered to 130 mph)^{1,2}

19" 5-segment-spoke design wheels (Silver finish) with 255/35 summer performance tires²

Rear-passenger thorax side airbags⁷

Carbon Atlas decorative inlays

Layered Aluminum/Black Wood decorative inlays

Fine Nappa leather seats and door armrests

Bang & Olufsen® Sound System (Premium Plus)

S4 available packages

Technology package (Premium Plus)

- ▶ MMI® navigation plus with voice control³
- ▶ Audi connect® with six-month trial subscription⁶
- ▶ Color driver information system
- ▶ SiriusXM® Traffic with four-year subscription³
- ▶ BLUETOOTH® streaming audio⁴
- ▶ Audi side assist
- ▶ Parking system with rear view camera

Driver Assistance package (Prestige)

- ▶ Dynamic steering
- ▶ Audi adaptive cruise control

High Gloss Black package

- ▶ 19" 5-V-spoke design wheels (Titanium finish) with 255/35 summer performance tires²
- ▶ Gloss Black Singleframe® grille
- ▶ Gloss Black trim around exterior side windows
- ▶ Body-colored exterior side mirror housings

S3 Specifications and Featured Content

S3 engineering/performance

2.0-liter turbocharged TFSI® four-cylinder

292 hp @ 5,400–6,200 rpm
280 lb-ft torque @ 1,900–5,300 rpm

0–60 mph in 4.7 sec/Top track speed of 155 mph¹

S3 Premium Plus featured highlights

Six-speed S tronic® dual-clutch transmission with steering wheel-mounted shift paddles

S3 sport suspension calibration

quattro® all-wheel drive

18" 5-arm-double-spoke S3 design wheels (Silver finish)

225/40 summer performance tires²

13.4" ventilated front and 12.2" ventilated rear disc brakes

Xenon plus headlights with LED daytime running lights

Automatic headlights

LED taillights and rear fog lights

S model quad exhaust outlets

S model exterior appearance (Platinum Gray Singleframe® grille, Aluminum-optic front/rear blades and exterior side mirror housings, body-colored extended side sills and integrated rear spoiler)

Dual-zone automatic climate control

Three-spoke multifunction flat-bottom sport steering wheel

Matte Brushed Aluminum decorative inlays

Aluminum door sill inlays

Black cloth headliner

Power windows with one-touch up/down operation and pinch protection

Panoramic sunroof

Leather seating surfaces

Heated twelve-way power front sport seats, including four-way power lumbar adjustment

Split-folding 60/40 rear seatbacks

Color driver information system

Audi concert radio with ten speakers and single CD player with MP3 playback capability

HD Radio™ Technology

SiriusXM® Satellite Radio with 90-day trial subscription³

Audi music interface with iPod® integration

BLUETOOTH® wireless technology preparation for mobile phone⁴

BLUETOOTH® streaming audio⁴

Audi advanced key—keyless start, stop and entry⁵

Audi drive select

S3 Prestige featured highlights (adds to or replaces features from S3 Premium Plus)

Full LED headlights

Power-folding exterior side mirrors (auto-dimming driver's side)

S3 Prestige featured highlights (continued)

Auto-dimming interior rear view mirror with digital compass

Ambient LED interior lighting

Interior Storage package

MMI® navigation plus with voice control³

MMI® touch with handwriting-recognition technology

Audi connect® with six-month trial subscription⁶

Bang & Olufsen® Sound System with 14 speakers and 705 watts

SiriusXM® Traffic with four-year subscription³

Audi side assist

Parking system plus with rear view camera (front and rear acoustic parking sensors)

S3 stand-alone options

Full LED headlights (Premium Plus)

225/40 all-season tires²

Rear-passenger thorax side airbags⁷

Bang & Olufsen® Sound System (Premium Plus)

Audi active lane assist (Premium Plus)

S3 available packages

Convenience package (Premium Plus)

- ▶ Power-folding exterior side mirrors (auto-dimming driver's side)
- ▶ Auto-dimming interior rear view mirror with digital compass
- ▶ Ambient LED interior lighting
- ▶ Interior Storage package

MMI® navigation plus package (Premium Plus)

- ▶ MMI® navigation plus with voice control³
- ▶ MMI® touch with handwriting-recognition technology
- ▶ Audi connect® with six-month trial subscription⁶
- ▶ SiriusXM® Traffic with four-year subscription³

Driver Assistance package (Premium Plus)

- ▶ Audi side assist
- ▶ Parking system plus with rear view camera

Advanced Technology package (Prestige)

- ▶ Audi adaptive cruise control with stop & go
- ▶ Audi active lane assist
- ▶ Audi pre sense® front

S Sport Seat package

- ▶ Fine Nappa leather seats with contrast diamond stitching
- ▶ Manually adjustable front sport-contoured seats
- ▶ Extended Leather package

Performance package

- ▶ Audi magnetic ride
- ▶ 19" 5-parallel-spoke design wheels (Polished/Anthracite finish)
- ▶ 235/35 summer performance tires²

¹ Top track speed is electronically limited in the U.S. Always obey all speed and traffic laws. ² See wheels page for important information regarding summer performance and low aspect ratio tires. ³ See back cover for important information regarding MMI® navigation plus and required SiriusXM® subscriptions. ⁴ Requires compatible device. ⁵ Some Audi models are equipped with a keyless ignition feature. The details as to how the system works can vary, and Audi owners should consult their owner's literature or an authorized Audi dealer if they have further questions about the operation of this feature. Please note that Audi warns against leaving the vehicle unattended with the engine running, particularly in enclosed spaces. ⁶ Always pay careful attention to the road, and do not drive while distracted. The features and technologies discussed above are optional, may require an additional subscription with separate terms and conditions, and should be used only when it is safe and appropriate. The Wi-Fi® hotspot feature is intended for passenger use only. ⁷ Airbags are supplemental restraints only and will not deploy in all crash circumstances. Always use safety belts and seat children only in the rear, using restraint systems appropriate for their size and age.

TTS Specifications and Featured Content

TTS engineering/performance
2.0-liter turbocharged TFSI® four-cylinder
265 hp @ 6,000 rpm 258 lb-ft torque @ 2,500 rpm
0–60 mph in 4.9–5.1 sec/Top track speed of 155 mph ¹
TTS featured highlights
ultra® lightweight technology—ASF® aluminum construction
Six-speed S tronic® dual-clutch transmission with steering wheel-mounted shift paddles
Audi magnetic ride
quattro® all-wheel drive
19" 5-parallel-spoke star design wheels (Silver finish)
255/35 summer performance tires ²
13.4" ventilated front and 12.2" ventilated rear disc brakes
Adaptive xenon plus headlights with LED daytime running lights
Headlight washing system
Automatic headlights
Front fog lights
Adaptive rear spoiler
S model quad exhaust outlets
S model exterior appearance (Platinum Gray Singleframe® grille, unique front/rear fasciae, and Aluminum-optic exterior side mirror housings)
Automatic climate control
Three-spoke multifunction flat-bottom sport steering wheel
Tilt and telescopic manually adjustable steering column
Matte Brushed Aluminum decorative inlays
Aluminum door sill inlays
Black cloth headliner
Power windows with pinch protection
Acoustic folding roof—folds at speeds up to 31 mph (Roadster)
Power-operated wind deflector (Roadster)
Silk Nappa leather seats
Heated twelve-way power front sport seats, including four-way power lumbar adjustment
2+2 seating arrangement (Coupe)
Split-folding 50/50 rear seatbacks (Coupe)
Driver information system with lap timer
BOSE® sound system with twelve speakers and AudioPilot® noise compensation
Single CD player with MP3 playback capability
SiriusXM® Satellite Radio with 90-day trial subscription ³
BLUETOOTH® wireless technology preparation for mobile phone ⁴
Garage door opener (HomeLink®)

TTS stand-alone options
Baseball-optic Fine Nappa leather seats and trim
Audi exclusive bicolor Fine Nappa leather seats and trim
TTS available packages
Audi navigation plus package
▶ Audi navigation plus ³
▶ Traffic information
▶ Audi music interface with iPod® integration
▶ Parking system with rear acoustic parking sensors
Black Optic package
▶ 19" 15-spoke design wheels (Titanium finish)
▶ Gloss Black Singleframe grille®
▶ Carbon fiber exterior side mirror housings
▶ Phantom Black decorative inlays
▶ Leather-wrapped roll-bars (Roadster)
Competition package
▶ 19" 5-arm-rotor design wheels (Silver finish)
▶ Fixed rear spoiler
▶ Front and rear brakes with Gray painted calipers
▶ Audi exclusive exterior paint (Imola Yellow or Nimbus Gray pearl)
▶ Audi exclusive Steel Gray Baseball-optic Fine Nappa leather seats with Imola Yellow stitching
▶ Extended Leather package with contrast stitching
▶ Parking system with rear acoustic parking sensors

SQ5 Specifications and Featured Content

SQ5 engineering/performance
3.0-liter supercharged TFSI® V6
354 hp @ 6,000–6,500 rpm 346 lb-ft torque @ 4,000–4,500 rpm
0–60 mph in 5.1 sec/Top track speed of 155 mph ¹
SQ5 Premium Plus featured highlights
Eight-speed Tiptronic® automatic transmission with steering wheel-mounted shift paddles
SQ5 sport suspension calibration
quattro® all-wheel drive
20" 5-parallel-spoke S design wheels (Silver finish)
255/45 summer performance tires ²
15.0" ventilated front and 13.0" ventilated rear disc brakes
Xenon plus headlights with LED daytime running lights
Automatic headlights
Front fog lights
LED taillights and rear fog lights
Power tailgate
S model quad exhaust outlets
S model exterior appearance (Platinum Gray Singleframe® grille and rear diffuser, Aluminum-optic exterior side mirror housings, body-colored extended side sills and integrated rear tailgate spoiler)
Three-zone automatic climate control
Three-spoke multifunction flat-bottom sport steering wheel
Tilt and telescopic manually adjustable steering column
Matte Brushed Aluminum decorative inlays
Aluminum door sill inlays
Front and rear floor mats
Black cloth headliner
Power windows with one-touch up/down operation and pinch protection
Panoramic sunroof
Leather/Alcantara® seating surfaces
Heated twelve-way power front sport seats, including four-way power lumbar adjustment
Driver seat memory
Sliding 40/20/40 split folding rear seat with adjustable recline
Driver information system
Audi concert radio with ten speakers and single CD player with MP3 playback capability
SiriusXM® Satellite Radio with 90-day trial subscription ³
Audi music interface with iPod® integration
BLUETOOTH® wireless technology preparation for mobile phone ⁴
Audi advanced key—keyless start, stop and entry ⁵
Audi drive select

SQ5 Prestige featured highlights (adds to or replaces features from SQ5 Premium Plus)

Adaptive xenon plus headlights with LED daytime running lights
Thermo cup holder
Manual rear-side window sunshades
MMI® navigation plus with voice control ³
Audi connect® with six-month trial subscription ⁶
Color driver information system
Bang & Olufsen® Sound System with 14 speakers and 505 watts
HD Radio™ Technology
SiriusXM® Traffic with four-year subscription ³
BLUETOOTH® streaming audio ⁴
Audi side assist
Parking system plus with rear view camera (front and rear acoustic parking sensors)

SQ5 stand-alone options

21" 5-double-spoke star design wheels (Polished/Titanium finish) with 255/40 summer performance tires ²
Rear-passenger thorax side airbags ⁷
Carbon Atlas decorative inlays
Layered Aluminum/Black Wood decorative inlays
Fine Nappa leather seats, door armrests and instrument panel top
Bang & Olufsen® Sound System (Premium Plus)
Panoramic sunroof deletion

SQ5 available packages

Technology package (Premium Plus)
▶ MMI® navigation plus with voice control ³
▶ Audi connect® with six-month trial subscription ⁶
▶ Color driver information system
▶ SiriusXM® Traffic with four-year subscription ³
▶ BLUETOOTH® streaming audio ⁴
▶ Audi side assist
▶ Parking system plus with rear view camera (front and rear acoustic parking sensors)
Driver Assistance package (Prestige)
▶ Dynamic steering
▶ Audi adaptive cruise control
Luxury package (Premium Plus and Prestige)
▶ Perforated Milano leather seats
▶ Leather door armrests and instrument panel top
▶ Ventilated front seats
High Gloss Black package (Premium Plus and Prestige)
▶ Gloss Black Singleframe® grille
▶ Matte Black aluminum roof rails
▶ Gloss Black trim around exterior side windows
▶ Body-colored exterior side mirror housings

1. Top track speed is electronically limited in the U.S. Always obey all speed and traffic laws. 2. See wheels page for important information regarding summer performance and low aspect ratio tires. 3. See back cover for important information regarding Audi navigation plus, MMI® navigation plus and required SiriusXM® subscriptions. 4. Requires compatible device. 5. Some Audi models are equipped with a keyless ignition feature. The details as to how the system works can vary, and Audi owners should consult their owner's literature or an authorized Audi dealer if they have further questions about the operation of this feature. Please note that Audi warns against leaving the vehicle unattended with the engine running, particularly in enclosed spaces. 6. Always pay careful attention to the road, and do not drive while distracted. The features and technologies discussed above are optional, may require an additional subscription with separate terms and conditions, and should be used only when it is safe and appropriate. The Wi-Fi® hotspot feature is intended for passenger use only. 7. Airbags are supplemental restraints only and will not deploy in all crash circumstances. Always use safety belts and seat children only in the rear, using restraint systems appropriate for their size and age.

Wheels

R8

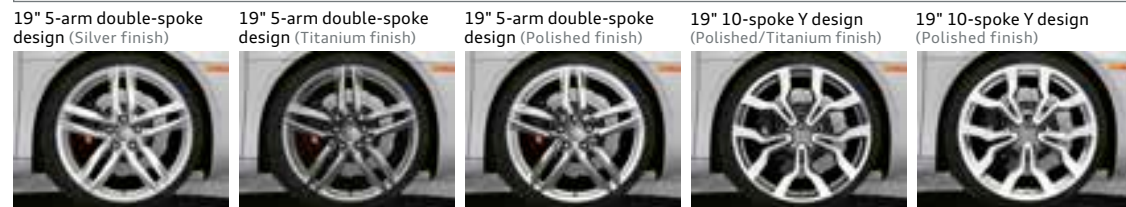

19" 5-arm double-spoke design (Silver finish) Front 235/35, rear 295/30 summer performance tires¹ V8
 19" 5-arm double-spoke design (Titanium finish) Front 235/35, rear 305/30 summer performance tires¹ V8, V10
 19" 5-arm double-spoke design (Polished finish) Front 235/35, rear 305/30 summer performance tires¹ V8, V10
 19" 10-spoke Y design (Polished/Titanium finish) Front 235/35, rear 295/30 summer performance tires¹ V10
 19" 10-spoke Y design (Polished finish) Front 235/35, rear 305/30 summer performance tires¹ V10



19" 5-double-spoke Y design (Titanium finish) Front 235/35, rear 295/30 summer performance tires¹ V10 plus
 19" 5-double-spoke Y design (Silver finish) Front 235/35, rear 295/30 summer performance tires¹ V10 plus

RS 7



20" 7-twin-spoke RS design (Silver finish) 275/35 summer performance tires¹
 21" 5-spoke-blade design (Silver finish) 275/30 summer performance tires¹
 21" 5-spoke-blade design (Titanium finish) 275/30 summer performance tires¹
 21" 5-spoke-blade design (Black finish) 275/30 summer performance tires¹

RS 5



19" 10-spoke RS design (Silver finish) 265/35 summer performance tires¹
 20" 5-arm-rotor design (Silver finish) 275/30 summer performance tires¹
 20" 5-arm-rotor design (Titanium finish) 275/30 summer performance tires¹
 20" 5-arm-rotor design (Matte Black finish) 275/30 summer performance tires¹
 20" 5-arm-rotor design (Matte Black finish and Red surround) 275/30 summer performance tires¹

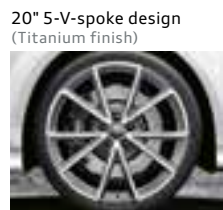

20" 5-V-spoke design (Titanium finish) 275/30 summer performance tires¹

High-performance tires are designed for better performance and handling in warm climates. When driving in cold, snowy or icy weather, you should equip your vehicle with four all-season or winter tires, which offer better traction under those conditions. We suggest you use the Audi-recommended winter or all-season tires specified for your Audi. High-performance tires also have a lower aspect ratio that aids performance and handling. Driving over rough or damaged road surfaces, as well as debris, curbs and other obstacles, can cause serious damage to wheels, tires, vehicle body and suspension parts. Be careful to avoid road hazards and reduce your speed, especially if your vehicle is equipped with low-profile tires. Please also remember when making your selection that, while these tires deliver responsive handling, they may ride less comfortably and make more noise than others. Finally, these tires may wear more quickly than other choices. It is important that the inflation pressure is regularly checked and maintained at recommended levels.

S8

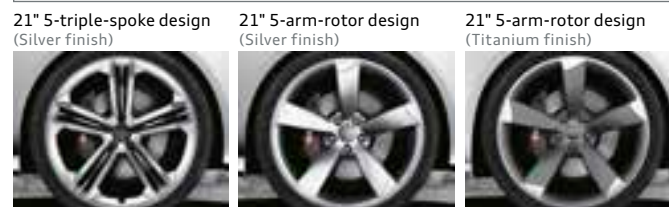

21" 5-triple-spoke design (Silver finish) 265/35 summer performance tires¹
 21" 5-arm-rotor design (Silver finish) 275/35 summer performance tires¹
 21" 5-arm-rotor design (Titanium finish) 275/35 summer performance tires¹

S6/S7

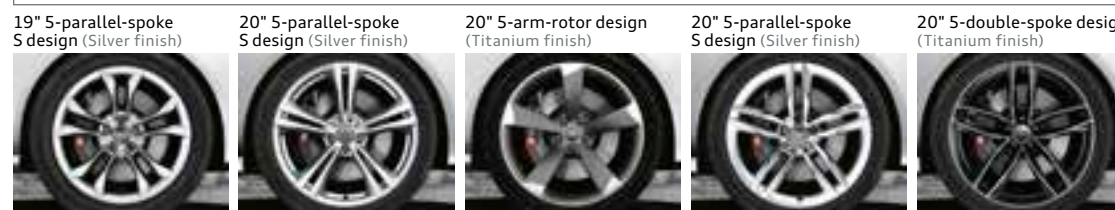

19" 5-parallel-spoke S design (Silver finish) 255/40 summer performance tires¹ S6, S7
 20" 5-parallel-spoke S design (Silver finish) 255/35 summer performance tires¹ S6
 20" 5-arm-rotor design (Titanium finish) 255/35 summer performance tires¹ S6
 20" 5-parallel-spoke S design (Silver finish) 265/35 summer performance tires¹ S7
 20" 5-double-spoke design (Titanium finish) 265/35 summer performance tires¹ S7

S5



18" 5-parallel-spoke S design (Silver finish) 245/40 summer performance tires¹ or available all-season tires (Coupe)
 19" 7-double-spoke RS design (Silver finish) 255/35 summer performance tires¹
 19" 5-arm-rotor design (Titanium finish) 255/35 summer performance tires¹
 19" 10-spoke Y design (Silver finish) 255/35 summer performance tires¹

S4



18" 5-parallel-spoke S design (Silver finish) 245/40 summer performance tires¹ or available all-season tires
 19" 5-segment-spoke design (Silver finish) 255/35 summer performance tires¹
 19" 5-V-spoke design (Titanium finish) 255/35 summer performance tires¹

S3



18" 5-arm-double-spoke S3 design (Silver finish) 225/40 summer performance tires¹
 19" 5-parallel-spoke design (Polished/Anthracite finish) 235/35 summer performance tires¹

TTS

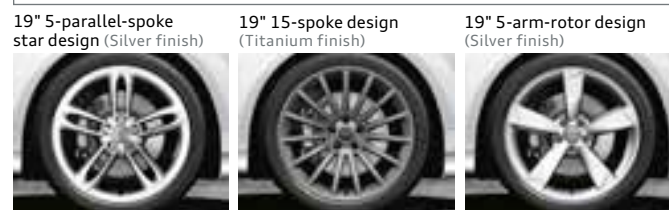

19" 5-parallel-spoke star design (Silver finish) 255/35 summer performance tires¹
 19" 15-spoke design (Titanium finish) 255/35 summer performance tires¹
 19" 5-arm-rotor design (Silver finish) 255/35 summer performance tires¹

SQ5



20" 5-parallel-spoke S design (Silver finish) 255/45 summer performance tires¹
 21" 5-double-spoke star design (Polished/Titanium finish) 255/40 summer performance tires¹

Interior Colors

R8

Black leather/Alcantara®



Titanium Gray leather/Alcantara®

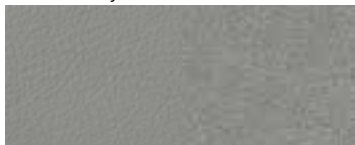

Black Fine Nappa leather

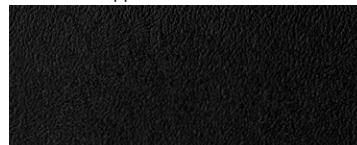

Titanium Gray Fine Nappa leather

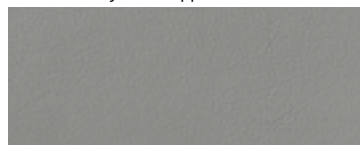

Lunar Silver Fine Nappa leather



Red Fine Nappa leather

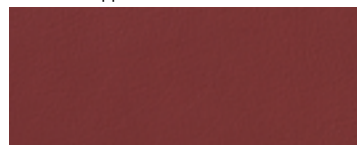

Nougat Brown Fine Nappa leather

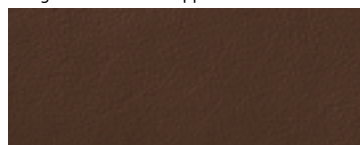

Luxor Beige Fine Nappa leather

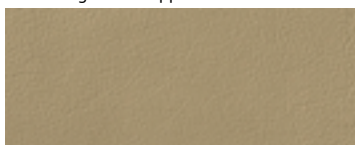

Black Fine Nappa leather with Beige contrast stitching

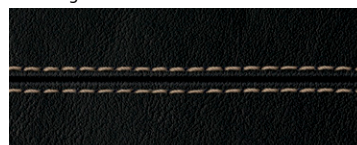

Black Fine Nappa leather with Red contrast stitching



Black Fine Nappa leather with Nougat Brown contrast stitching

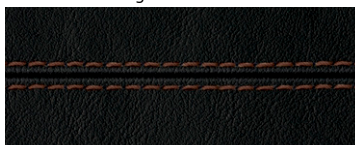

Black Fine Nappa leather with Madras Orange contrast stitching

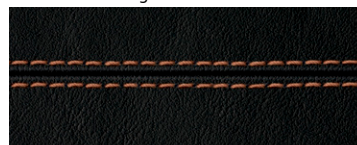

Black Fine Nappa leather with Silver contrast stitching

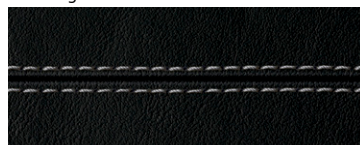

Black Fine Nappa leather with Silver contrast diamond stitching



Titanium Gray Fine Nappa leather with Steel Gray contrast diamond stitching



RS 7

Black Valcona leather with Silver contrast honeycomb stitching



Lunar Silver Valcona leather with Steel Gray contrast honeycomb stitching



Black Perforated Valcona leather

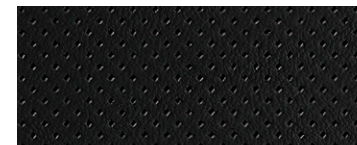

S8

Black Perforated Valcona leather with diamond quilting

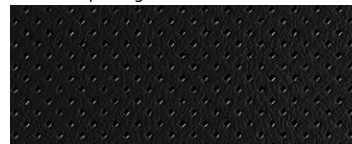

Nougat Brown Perforated Valcona leather with diamond quilting

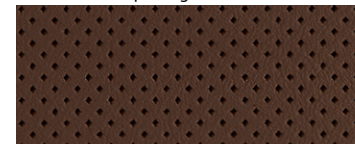

Titanium Gray Perforated Valcona leather with diamond quilting



Velvet Beige Perforated Valcona leather with diamond quilting



Lunar Silver Perforated Valcona leather with diamond quilting and Steel Gray stitching and piping



Balao Brown Perforated Valcona leather with White stitching and piping



Vermont Brown Perforated Valcona leather with diamond quilting and Granite Gray stitching and piping

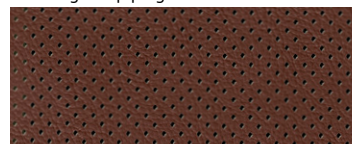

Audi design selection

Audi design selection

S6/S7

Black Valcona leather with Silver contrast diamond stitching



Lunar Silver Valcona leather with Steel Gray contrast diamond stitching

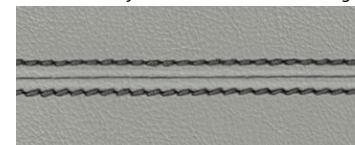

Black Perforated Valcona leather

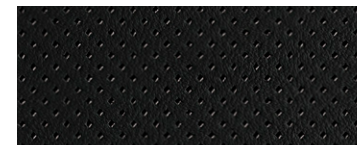

Interior Colors (continued)

S4/S5/RS 5

Black leather/Alcantara®



S4, S5 Coupe, RS 5 Coupe

Black leather/Lunar Silver Alcantara®



S4, S5 Coupe

Black Fine Nappa leather

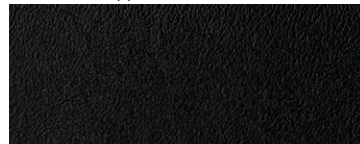

S4, S5, RS 5

Black/Lunar Silver Fine Nappa leather

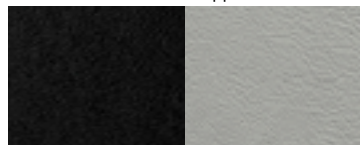

S4, S5

Black/Magma Red Fine Nappa leather



S4, S5

Black/Chestnut Brown Fine Nappa leather

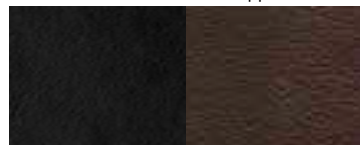

S4, S5

Black Perforated Milano leather



S5, RS 5

Chestnut Brown Perforated Milano leather



S5

Lunar Silver Fine Nappa leather



RS 5

S3

Black leather



Black/Titanium Gray leather

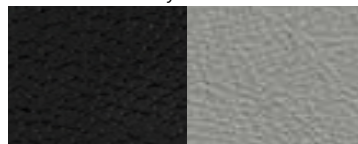

Black/Magma Red leather

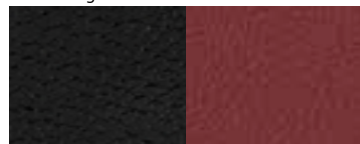

Black Fine Nappa leather with Dark Silver contrast diamond stitching

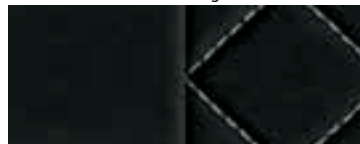

TTS

Black Silk Nappa leather

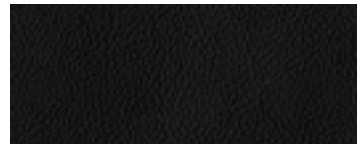

Black/Spectral Silver Silk Nappa leather



Black/Orange Silk Nappa leather



Black/Magma Red Silk Nappa leather



Black/Titanium Gray Fine Nappa leather

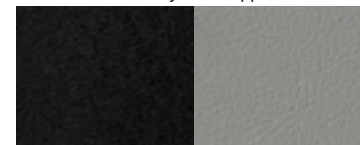

Audi exclusive

Black/Crimson Red Fine Nappa leather



Audi exclusive

Madras Brown Baseball-optic Fine Nappa leather



Steel Gray Baseball-optic Fine Nappa leather with Imola Yellow contrast stitching



Audi exclusive

SQ5

Black leather/Alcantara®



Black leather/Lunar Silver Alcantara®



Black Fine Nappa leather

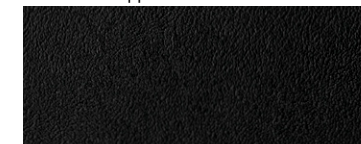

Black/Lunar Silver Fine Nappa leather



Black/Magma Red Fine Nappa leather



Black/Chestnut Brown Fine Nappa leather



Black Perforated Milano leather



Chestnut Brown Perforated Milano leather



Decorative Inlays

Matte Brushed Aluminum¹



S3, S4, S5, S6, S7, TTS, SQ5

Phantom Black¹



TTS

Carbon Atlas¹



S4, S5, S6, S7, S8, SQ5

Layered Aluminum/Black Wood¹

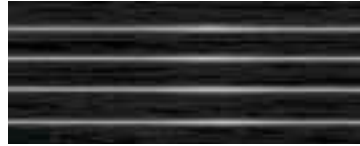

S4, S5, S6, S7, RS 7, SQ5

Fine Grain Ash Natural Brown Wood¹



S6, S7

RS design Carbon Fiber¹

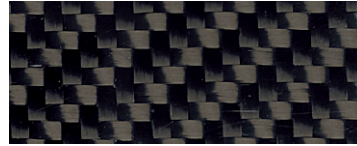

RS 5, RS 7

Aluminum Race¹



RS 5, RS 7

Carbon Atlas/Brushed Aluminum¹

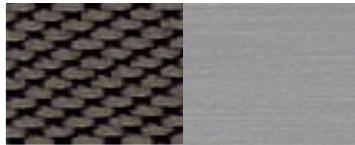

S8

Dark Brown Walnut Wood/Brushed Aluminum¹

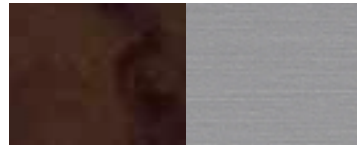

S8

Assam Gray Vavona Wood/
Brushed Aluminum¹

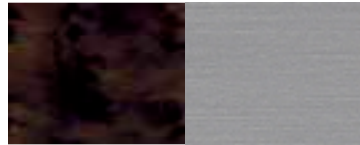

S8

Brown/Silver Poplar Wood/Brushed Aluminum¹

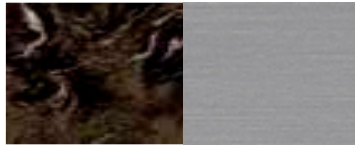

S8

Velvet Brown Fine Grain Ash Wood/
Brushed Aluminum¹

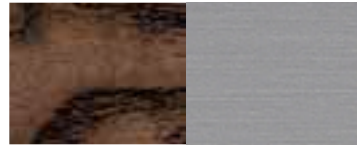

S8

Balsamic Brown Natural Fine Grain Ash
Wood/Brushed Aluminum¹



S8

Carbon Copper Twill/Brushed Aluminum¹



S8

Black Silk Matte¹



R8

Piano Black¹

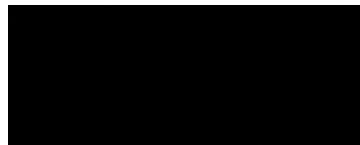

R8

Carbon Sigma¹

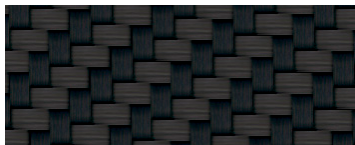

R8

Colored in bold strokes.

¹ Decorative inlay options will vary based on model and interior color combination.

Exterior Colors

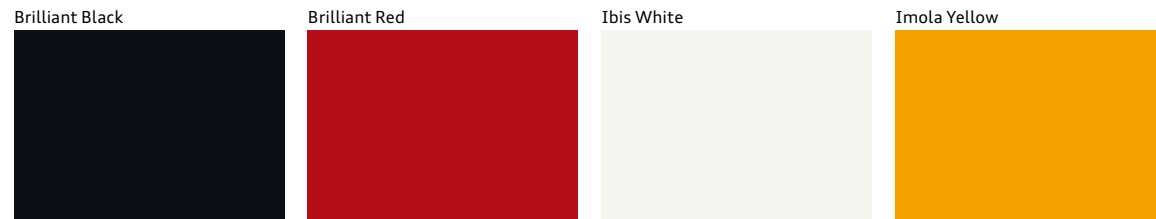

Brilliant Black
S3, S4, S5, S6, S7, S8, TTS, SQ5



Brilliant Red
R8



Ibis White
S4, S5, S6, S7, S8, RS 5 Coupe, RS 7, TTS, R8, SQ5

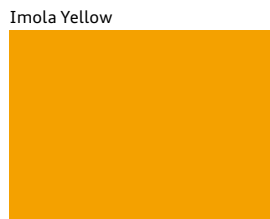

Imola Yellow
TTS

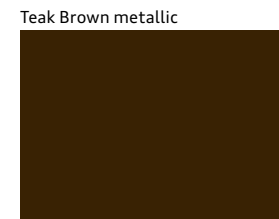

Teak Brown metallic
R8

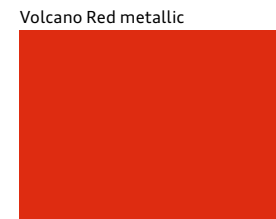

Volcano Red metallic
S4, S5, TTS, SQ5

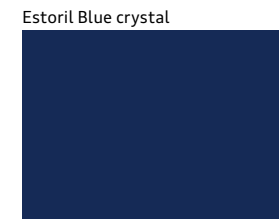

Estoril Blue crystal
RS 7

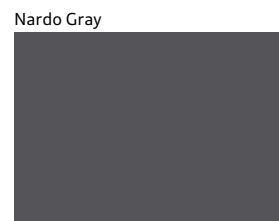

Nardo Gray
RS 5 Cabriolet, RS 7

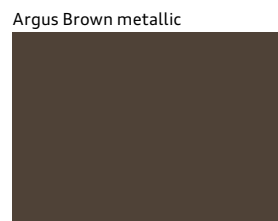

Argus Brown metallic
S8



Beluga Brown metallic
S3

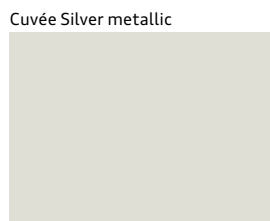

Cuvée Silver metallic
S8

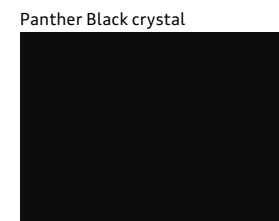

Panther Black crystal
S3, RS 5, RS 7, TTS Coupe, R8, SQ5

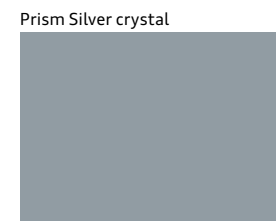

Prism Silver crystal
RS 7



Daytona Gray pearl
S4, S5, S8, RS 5, RS 7, R8, SQ5

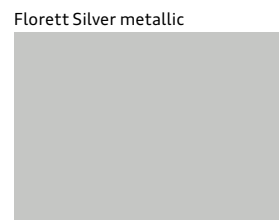

Florett Silver metallic
S3, S4, S5, S8, SQ5

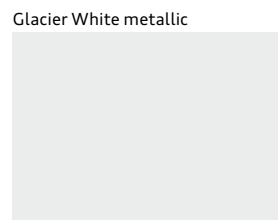

Glacier White metallic
S3, S4, S5, S6, S7, S8, RS 5 Cabriolet, TTS, SQ5



Havana Black metallic
S6, S7, S8

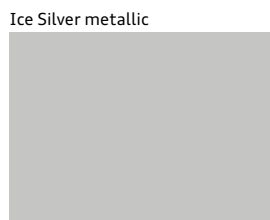

Ice Silver metallic
S6, S7, TTS, R8



Garnet Red pearl
S6, S7



Lava Gray pearl
SQ5



Misano Red pearl
S3, S4, S5, RS 5, RS 7, TTS



Monsoon Gray metallic
S3, S4, S5, S8, SQ5

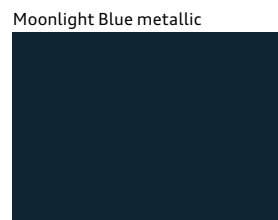

Moonlight Blue metallic
S4, S5, S6, S7, S8, SQ5



Mythos Black metallic
S3, S4, S5, RS 5, SQ5



Oolong Gray metallic
S6, S7, S8, TTS

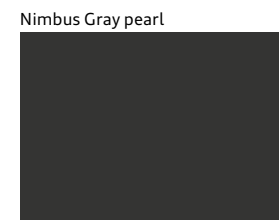

Nimbus Gray pearl
TTS

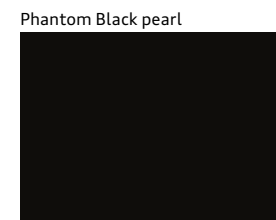

Phantom Black pearl
S6, S7, S8, RS 7, TTS, R8



Sepang Blue pearl
S3, S4, S5, S6, RS 5, R8, SQ5

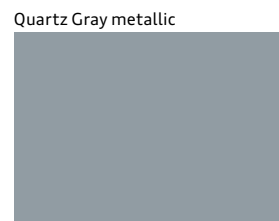

Quartz Gray metallic
S6, S7

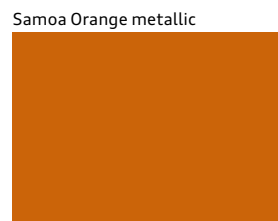

Samoa Orange metallic
TTS, R8

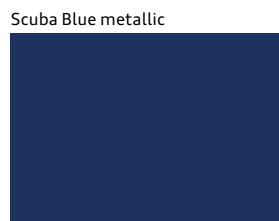

Scuba Blue metallic
TTS

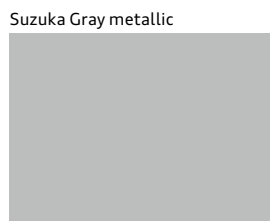

Suzuka Gray metallic
RS 5 Coupe, RS 7, R8



Daytona Gray matte
RS 7



Sepang Blue matte
R8 V10 plus

Note: A word about this brochure. Audi of America, Inc., believes the specifications in this brochure to be correct at the time of printing. However, specifications, standard equipment, options, fabrics, and colors are subject to change without notice. Some equipment may be unavailable when your vehicle is built. Please ask your dealer for advice concerning current availability of standard and optional equipment, and your dealer will verify that your vehicle will include the equipment you ordered. Vehicles in this brochure are shown with optional equipment. See your dealer for complete details on the Audi New Vehicle Limited Warranty, twelve-year limited warranty against corrosion perforation, and Audi 24/7 Roadside Assistance. (Roadside assistance coverage provided by Road America in the U.S. Certain conditions apply; see your dealer for details.) Tires supplied by various manufacturers. "Audi," all model names, "ASF," "Audi connect," "Audi pre sense," "Audi Sport," "cylinder on demand," "DRC," "e-tron," "FSI," "MMI," "quattro," "Singleframe" and the Singleframe grille design, "S line," "S tronic," "TFSI," "Truth in Engineering," "ultra," and the four rings logo are trademarks or registered trademarks of AUDI AG. "Alcantara" is a registered trademark of Alcantara S.p.A. "Bang & Olufsen" is a registered trademark of Bang & Olufsen. The BLUETOOTH word mark and logos are owned by the Bluetooth SIG, Inc., and any use of such marks by AUDI AG is under license. "BOSE" and "AudioPilot" are registered trademarks of the BOSE Corporation. "Google" and "Google Earth" are trademarks of Google Inc. "HD Radio" and the HD Radio logo are proprietary trademarks of iBiquity Digital Corporation. "Homelink" is a registered trademark of Johnson Controls Technology Company. "iPod" is a registered trademark of Apple Inc. "SiriusXM" and all related marks and logos are trademarks of Sirius XM Radio Inc. and its subsidiaries. "Tiptronic" is a registered trademark of Dr. Ing h.c. F. Porsche AG. "Wi-Fi" is a registered trademark of the Wi-Fi Alliance. All other trademarks are the property of their respective owners. Some European models shown.

Audi navigation plus and MMI® navigation plus depend on signals from the worldwide Global Positioning Satellite network. The vehicle's electrical system and existing wireless and satellite technologies must be available and operating properly for the system to function. The system is designed to provide you with suggested routes in locating addresses, destinations and other points of interest. Changes in street names, construction zones, traffic flow, points of interest and other road system changes are beyond the control of Audi of America, Inc. Complete detailed mapping of lanes, roads, streets, toll roads, highways, etc., is not possible, therefore you may encounter discrepancies between the mapping and your actual location. Please rely on your individual judgment in determining whether or not to follow a suggested navigation plus route. For mapping updates please see your Audi dealer or call 1-800-FOR-AUDI for details.

SiriusXM Satellite Radio and SiriusXM Traffic subscriptions are sold separately or as a package after trial period and are continuous until you call SiriusXM to cancel. See Customer Agreement for complete terms and more information at www.siriusxm.com. SiriusXM Traffic service available in select markets. SiriusXM U.S. Satellite Service available only to those in the 48 contiguous U.S.A., D.C. and Puerto Rico (with coverage limitations).

2015 | Sport

Audi of America
Audiusa.com
Facebook.com/Audi

AoA1515494

© 2014 Audi of America, Inc. Printed in the U.S.A.