



Porsche Cars North America, Inc.
 980 Hammond Drive, Suite 1000
 Atlanta, Georgia 30328

Dr. Ing. h.c. F. Porsche AG is the owner of numerous trademarks, both registered and unregistered, including without limitation the Porsche Crest®, Porsche®, Boxster®, Carrera®, Cayenne®, Cayman®, Panamera®, Speedster®, Spyder®, Tiptronic®, VarioCam®, PCM®, PDK®, 911®, RS® 4S®, 918 Spyder®, FOUR, UNCOMPROMISED®, and the model numbers, and the distinctive shapes of the Porsche automobiles, such as the federally registered 911 and Boxster automobiles. The third-party trademarks contained herein are the properties of their respective owners. Porsche Cars North America, Inc., believes the specifications to be correct at the time of printing. Specifications, performance standards, standard equipment, options, and other elements shown are subject to change without notice. Some options may be unavailable when a car is built. Some vehicles may be shown with non-U.S. equipment. Please ask your dealer for advice concerning the current availability of options and verify the optional equipment that you ordered. Porsche recommends seat-belt usage and observance of traffic laws at all times.

All fuel consumption and emissions data contained herein are derived from U.S. tests and were accurate at time of press.
 ©2013 Porsche Cars North America, Inc. Printed in the U.S.A.



MKT 001 027 13

porscheusa.com

1-800-PORSCHE

The new 911 Turbo

MKT 001 027 13



The new 911 Turbo



Benchmark: the 911 Turbo	4
Concept	6
Design	10
Engineering	14
The new 911 Turbo	15
The new 911 Turbo S	18
The new 911 Turbo Cabriolet and 911 Turbo S Cabriolet	21
Power	25
Engine	28
Transmission	35
Chassis	47
Lighting	57
Responsibility	60
Brakes	62
Environment	67
Personality	72
Comfort	74
Audio and communication	84
Personalization	89
Porsche Driving Experience	107
Panorama	109
The sum of our experience	111
Technical data	113
Index	115



Benchmark: the 911 Turbo.

When Porsche unveiled the first 911 Turbo 40 years ago, it instantly became the new benchmark of high performance. Through four decades of engineering evolution, and through countless victories across the world of motorsports, the 911 Turbo has remained our benchmark—for everything that Porsche builds. With each new 911 Turbo, the starting point for getting to the very limit of what's possible is reset. Once again.



At Porsche, we prefer to lead by example.

The 911 Turbo.

Given that the starting point is the most recent 911 Turbo, how do you make a new 911 Turbo that performs at an even higher level?

How do you make its engine produce more power with less fuel? Its transmission shift more seamlessly, its suspension grip the road with more traction, and its brakes shed speed with even more force and less fade? Its exterior more aerodynamic and its interior more functional and comfortable? How do you make its safety engineering more advanced?

How do you, in other words, evolve the legendary 911 Turbo and enhance its capabilities—without diluting its essential character?

It's a daunting challenge, yet one Porsche engineers confront with clear-eyed goals and race-proven technical innovations.

There are measurable objectives: improved g-force, horsepower, and torque outputs, shorter braking distances, and quicker zero-to-sixty times. And there are more subjective

considerations: the sound of the engine, the support of the seats, the feeling of confidence and control that results from a total synergy between car and driver.

It's a process that requires, above all, patience. A new technology may take time to translate its advantages to meet the aims of a Porsche. A promising idea may prove less so when subjected to our test circuit at Weissach or to the extreme demands of endurance races like the 24 Hours of Le Mans or the Twelve Hours of Sebring.

But the reward for following a highly disciplined process is unquestionable. With each successive 911 Turbo, Porsche engineers have demonstrated that ever-higher levels of performance remain to be discovered.

And the new 911 Turbo is no exception. With 90 percent of its components redeveloped, it once again provides a new reference for Porsche excellence.

Our engineers have been measuring themselves against their dreams for 50 years. When Porsche unveiled the first 911 Turbo at the 1974 Paris Motor Show, people shook their heads in disbelief. With just six cylinders and a mere 3-liter displacement, how could such a relatively small engine produce such a prodigious amount of power?

The answer, of course, was turbocharging, and the quizzical headshaking soon gave way to appreciation for the achievement of a fundamental technical breakthrough. It quickly became clear that the 911 Turbo was going to be a reference for all other sports cars—even our own.

The bar was set high. And with every new generation, the challenge for Porsche engineers has been to raise it still higher.

What distinguishes a 911 Turbo at its heart is the absolute desire for performance—Intelligent Performance. It's a personality trait that makes every 911 Turbo stand out from the crowd. And sets new standards for sports car performance with each evolution—in form and in function.

It is a Porsche made for the racetrack, turned into a sports car for everyday use. It is power that accepts responsibility—with a high level of safety and reduced impact on the environment.

The new 911 Turbo offers greater engine power. Its improved Porsche Doppelkupplung (PDK) now comes as standard. Its thermal management is improved. Its handling enhanced with the new rear-axle steering and Porsche Active Aerodynamics (PAA), used here for the very first time in a road car.

The new 911 Turbo shows that, if you measure yourself against your own dreams, there's no limit to what is possible.

The 911 Turbo has been the benchmark since 1974. And now, in the latest generation, it has found its most powerful expression.





**Starts off on graph paper.
Doesn't fit into any grid.**

Design.

A lot of designed objects make a stunning debut. Very few achieve lasting impact.

Design can only endure if form is not just a shell. If form truly follows function, then that object cannot—should not—be anything else. When that ideal is realized, the result is something truly timeless; something that will serve as the essential reference point for everything that comes after it.

There can be no doubt about the origin of the new 911 Turbo. In its form, proportions, and lines, it is clearly evolved from all previous 911 Turbo models. The changes are subtle yet profound. The fenders are higher than the front hood; the extra inch at the back compared to previous models creates an especially dynamic tension. Height and overhangs have been reduced, while the wheelbase is approximately four inches longer, improving stability and stretching the characteristic arc of the 911 roofline.

The new 911 Turbo looks more powerful, more agile, sportier.

An iconic feature of the 911 Turbo is the rear aerodynamic wing. In the new 911 Turbo, it's been completely revised and, together with the adaptive spoiler at the front, forms the completely new Porsche Active Aerodynamics (PAA) system.

The design of the new 911 Turbo Cabriolet is also resetting standards in both form and function. The integrated supporting magnesium elements of the fabric top are lightweight yet rigid to help the Cabriolet retain the distinctive form of the 911 when the top is up. And at the same time, they help make it extremely stable, to enhance the structural rigidity of the chassis that is so essential to a Porsche sports car.



1

Forged, and featuring a high-quality two-tone look, the standard wheels are one inch larger than those on previous models—20 inches in diameter on all 911 Turbo models. On the 911 Turbo S and 911 Turbo S Cabriolet, new standard wheels are also half an

inch wider and have a central locking device derived from motorsport.

Another standard feature on the new 911 Turbo S models is the nose panel with additional air blades and the SportDesign exterior mirrors



2

with V-shaped base. Their delicate appearance proves that performance isn't just a question of brute power—it demands design finesse.

The new LED headlights, standard on the Turbo S models, feature Porsche

Dynamic Light System Plus (PDLS Plus). They use less energy—another example of Intelligent Performance—and give the S models an even more memorable look. They are also available as an option for the 911 Turbo and the new 911 Turbo Cabriolet.



3

Inside, the evolution of the 911 Turbo continues. The newly designed interior is focused on just one thing: the driver. All of the information comes together behind the steering wheel. The rising central console is impressive with an intelligent operating concept and clever ergonomics.

Sportiness and comfort are combined in the Power Sport Seats, fitted as standard in the 911 Turbo models. The emphasis is placed firmly on “sport” by the Adaptive Sport Seats Plus with 18-way adjustment, fitted as standard in the 911 Turbo S models. All models

have power steering-column adjustment and driver memory package as standard.

A feature that distinguishes the 911 Turbo S models is the exclusive two-tone interior in Black and Carrera Red, combined with the Carbon interior trim package.

And, thanks to the many personalization options, you can set your own personal standards in the interior, with a wide range of different interior colors and materials, such as Wood, Leather, Aluminum, or Carbon.

1 SportDesign exterior mirror | 2 911 Turbo S front panel with air blades

3 911 Turbo S interior in Black and Carrera Red



**The laws of physics.
Reinterpreted.**

Engineering.

The heart of the new 911 Turbo models—located at the rear, as always—is Porsche's 6-cylinder boxer engine. Displacing 3.8 liters, it uses twin turbochargers with Variable Turbine Geometry (VTG) and provides more power than ever before. It's a more efficient engine too, thanks to new technologies including thermal management, electrical system recuperation, and features such as Auto Start Stop, an improved Porsche Doppelkupplung (PDK), and coasting function.

Another new standard feature of the new 911 Turbo is rear-axle steering. Improving both agility and stability, rear-axle steering adapts to different driving situations. On 911 Turbo S models, Porsche Dynamic Chassis Control (PDCC) is also standard. PDCC actively adjusts chassis characteristics to elevate the ability of the 911 Turbo S to hold the road, both in a straight line and when cornering.

And in the new 911 Turbo, the Porsche Active Aerodynamics (PAA) system

makes its transfer from the racetrack to a production Porsche for the first time. PAA adjusts the settings of both the front and the rear spoiler. The result is greater stability, lower fuel consumption on the road, and impressive times on the racetrack.

More power. Greater efficiency. Enhanced chassis control and aerodynamics. In addition, all new 911 Turbo models also include as standard a reversing

camera and Adaptive Cruise Control including Porsche Active Safe (PAS).

LED headlights, including Porsche Dynamic Light System Plus (PDLS Plus), are standard in the 911 Turbo S models and optional on the 911 Turbo and the new 911 Turbo Cabriolet. They provide excellent orientation and make driving much less tiring.

Four decades of refinement.

Distilled down into a mere three seconds.

The new 911 Turbo.

To Porsche engineers, the 911 Turbo has always been about turning the theoretical into the phenomenal. It has been relentless work, with countless long hours over the decades spent seeking incremental improvements, fighting for every gram of weight reduction, every increase in horsepower, and every split second of speed. Each breakthrough has pushed the limits of possibility, and each stage has established the next starting point.

Once again we have arrived at an entirely new 911 Turbo, with more power than that of previous models: 520 horsepower at 6000–6500 rpm and a maximum torque of 487 lb.-ft. The sprint from 0–60 mph can be achieved in as little as 3.2 seconds. The optional Sport Chrono Package reduces this figure even more: to just 3.0 seconds. And the new 911 Turbo now uses Porsche Active Aerodynamics (PAA) to dynamically optimize the level of traction at speed.

The power of its new 3.8-liter twin-turbo engine combined with Porsche Doppelkupplung (PDK) and active all-wheel-drive Porsche Traction Management (PTM) results in a new 911 Turbo with a top track speed of 195 mph.

A trio of technologies help the new 911 Turbo balance handling precision with ride comfort. They feature new rear-axle steering, Porsche Active Suspension Management (PASM), and Porsche Torque Vectoring Plus (PTV Plus) including rear differential lock.

At each corner of the new 911 Turbo are 20-inch, 10-spoke wheels in a unique two-tone combination.

The interior follows one clear line: sporty, yet comfortable. Leather trim is standard as are the Power Sport Seats including electric steering-column adjustment. Porsche Communication Management (PCM) with navigation module brings all information together clearly and has intuitive controls. The Bose® Surround Sound System enhances the typical Porsche melody with another impressive symphonic experience.





Somehow, Porsche engineers always find a higher level of performance.

The new 911 Turbo S.

Good enough is simply not in the DNA of a Porsche engineer. There is always more performance to be found, more boost to be dialed up, another plateau of driving precision to be discovered.

And when those objectives are reached, Porsche typically marks them with an “S.”

Witness the new 911 Turbo S. Its 3.8-liter, 6-cylinder, twin-turbo engine delivers 560 horsepower between 6500 and 6750 rpm—that’s 40 horsepower more than on the new 911 Turbo. The maximum torque is 553 lb.-ft. with overboost, a function of the standard Sport Chrono Package. The benchmark sprint from 0–60 mph takes a mere 2.9 seconds. The top track speed is 197 mph.

In the new 911 Turbo S, power is transmitted by the 7-speed Porsche Doppelkupplung (PDK) to the active all-wheel-drive Porsche Traction Management (PTM). The Sport Chrono Package includes dynamic engine mounts fitted as standard. Porsche Active Aerodynamics (PAA) aids high-speed stability by enabling dynamic adjustment of the front and the rear spoilers.

The 911 Turbo S also deploys the new rear-axle steering. This combines the exceptional agility expected of a high-performance sports car with the driving ease that allows the new 911 Turbo owner to enjoy everyday practicality.

The 911 Turbo S comes standard with Porsche Dynamic Chassis Control (PDCC). Together with Porsche Active Suspension Management (PASM)—a system that electronically adjusts the firmness of the shock absorbers—and Porsche Stability Management (PSM), it ensures that the 911 Turbo S sets new standards in terms of chassis control.

Composure is also generated by the Porsche Ceramic Composite Brakes (PCCB). This high-performance braking system first proved its stopping power and durability on the racetrack and is now standard on the 911 Turbo S.

In the 911 Turbo S interior, exclusive materials create a unique impression: the two-tone Leather interior package in Black and Carrera Red. The interior

trim in Carbon. The door-entry guards with the “turbo S” logo. The Adaptive Sport Seats Plus with 18-way adjustment, driver seat memory, and Leather-covered backrest shell with double seam.

High levels of comfort are provided by other standard features, including cruise control, front and rear ParkAssist, and the new LED headlights in conjunction with the Porsche Dynamic Light System Plus (PDLS Plus).

The new 911 Turbo S is identifiable at the rear by the “turbo S” logo and the dark chrome tailpipe trim, and at the side by the new SportDesign exterior mirrors with V-shaped base. At all four corners forged 20-inch 911 Turbo S wheels are highlighted by a central locking device perfected on Porsche race cars.

Performance that generates composure. At Porsche, it's not a paradox. It's standard in the new 911 Turbo S.



The power of air.

As applied by Porsche.

The new 911 Turbo Cabriolet and 911 Turbo S Cabriolet.

The 911 Turbo is an exercise in exploiting the power of air. The new 911 Turbo Cabriolet and Turbo S Cabriolet? All the more so.

The newly developed fabric cabriolet top and electric wind deflector in the 911 Turbo Cabriolet models provide the best conditions for plenty of fresh air. The key points: They are convenient and quick to operate, create little drag while driving, and there is minimal wind noise. And now, for the first time in a Turbo Cabriolet, the 911 silhouette is just as unmistakable as in a 911 Turbo Coupe.

Both models are driven by a 3.8-liter twin-turbo engine. In the new 911 Turbo Cabriolet, it develops 520 horsepower at 6000–6500 rpm and a maximum torque of 487 lb.-ft. The top track speed is 195 mph and it reaches its 60-mph mark in just 3.3 seconds.

With an additional 40 horsepower, the engine in the new 911 Turbo S Cabriolet delivers even more, specifically: 560 horsepower between 6500 and 6750 rpm. The maximum torque, with overboost, is 553 lb.-ft., enabling a top speed of 197 mph and a

breathtaking sprint from 0–60 mph in a mere 3.0 seconds.

The enhanced Porsche Doppelkupplung (PDK) transmission is precise and direct, transmitting power to all four wheels via the active all-wheel-drive capabilities of Porsche Traction Management (PTM). Rear-axle steering helps further the aim of handling precision.

Another way to tap the power of air? Porsche Active Aerodynamics (PAA). It's an innovation Porsche developed for the racetrack, where rapid changes in downforce dynamics can poise a

challenge to high-speed stability. The solution is the active adjustment of the front and rear spoilers to constantly optimize aerodynamic downforce over the front and rear axles.

The new 911 Turbo Cabriolet boasts 20-inch two-tone wheels as standard, while on the new 911 Turbo S Cabriolet, 20-inch two-tone 911 Turbo S wheels with central locking device are standard. All wheels are forged and polished on the front.

The new 911 Turbo Cabriolet models: our new benchmark for open-top driving.





Cabriolet Top

The fabric roof in the new 911 Turbo Cabriolet models has been completely revised. It uses three integrated supporting elements made from magnesium. Light yet strong, the magnesium components make the top extremely stable at high speeds—without adding unnecessary weight.

The magnesium structure also creates a top that is smooth and taut. The fabric is close-fitting and forms a line that is even more elegant than in the previous model. Yet the benefit is far from being just superficial. The firm fabric roof of the new 911 Turbo Cabriolet models helps achieve a drag coefficient of just 0.31.

The glass rear window is scratch-resistant and heated. A water-deflecting edge on the top helps prevent rainwater from dripping onto you when you open the doors.

The top is operated electrically by a button in the center console, and it opens or closes in approximately 13 seconds—at speeds of up to 31 mph. The top folds in a Z-shape so the inside is always well-protected.

Inside, the roof is covered with heat- and noise-insulating material, resulting in uniform interior temperatures and effective wind noise suppression. What do you hear instead? That unmistakable sound of the Porsche Turbo exhaust note.

Electric Wind Deflector

Developed in a wind tunnel and made for relative wind: The 911 Turbo Cabriolet models come standard with a new electric wind deflector. This ensures that you can drive with the top down with minimal wind noise, and without sacrificing the car's low drag coefficient. You can extend and retract the wind deflector at speeds of up to 75 mph—at the press of a button and in only two seconds.

Manually fitting and removing the wind deflector is no longer necessary. It is now integrated directly into the body and rests behind the back seats, so it does not need any additional space inside the vehicle or in the luggage compartment and is ready to use at any time.

Power.

For Porsche, power and weight have always been viewed as part of the same equation. Turbocharging is a way to create a dramatic increase in power, without adding the bulk of a big displacement engine. And then there is the question of where to place the engine's mass. In the new 911 Turbo, it is where you'd expect Porsche to put it: at the rear. Together with countless other innovations, these two fundamental aspects of the 911 Turbo—its turbocharged power, rear-mounted—create a performance character for which there simply is no substitute.





The essential ingredients are familiar.

Yet transformation is phenomenal.

Engine.

The new 911 Turbo engine adheres to proven Porsche principles: rear-mounted. With six cylinders and a total displacement of 3.8 liters. And the cylinders placed horizontally in two opposite rows—what’s referred to as a “flat-six” arrangement. It does not deviate from this formula because the typical Porsche “boxer” construction and the rear-mounted position of the engine create numerous advantages: excellent balancing of masses as dynamic loads change, a low-vibration drive, and a low center of gravity.

But what ultimately transforms a Porsche into a 911 Turbo are its two exhaust-driven turbochargers. Together with Variable Turbine Geometry (VTG), the intake manifold, and VarioCam Plus, the forced induction of compressed air into the cylinders creates stunning performance. On paper or on pavement, there is nothing like a Porsche 911 Turbo.

The new 911 Turbo and the new 911 Turbo Cabriolet deliver 520 horsepower available between 6000 and 6500 rpm, and 487 lb.-ft. of

torque between 1950 and 5000 rpm (and briefly up to 524 lb.-ft. with the overboost function that comes with the optional Sport Chrono Package).

The 911 Turbo S models have 560 horsepower available between 6500 and 6750 rpm. The maximum torque is 516 lb.-ft., from 2100–4250 rpm. And it can increase to 553 lb.-ft., thanks to the overboost function that comes with the Sport Chrono Package, which is standard on Turbo S models.

This is efficient performance, thanks to intelligent innovations that keep the vehicle weight low and make optimal use of fuel. These include new efficiency-enhancing measures such as thermal management, electrical system recuperation, the Auto Start Stop function, and the coasting function.

Both versions of the new engine have Direct Fuel Injection (DFI). DFI injects the fuel directly into the combustion chamber with millisecond precision. Injection and taper angle are optimized for torque, performance, consumption, and emissions. The engine control system adjusts the injection timing individually for each cylinder and the injection quantity for each cylinder bank. The greater compression this

achieves provides more power—and makes the engine more efficient. The integrated dry-sump lubrication ensures reliable oil supply and also performs additional cooling functions. The electronic oil pump supplies oil when it is needed. And because the oil reservoir is integrated in the engine, there is no need for an external oil tank. This saves space and, above all, weight.

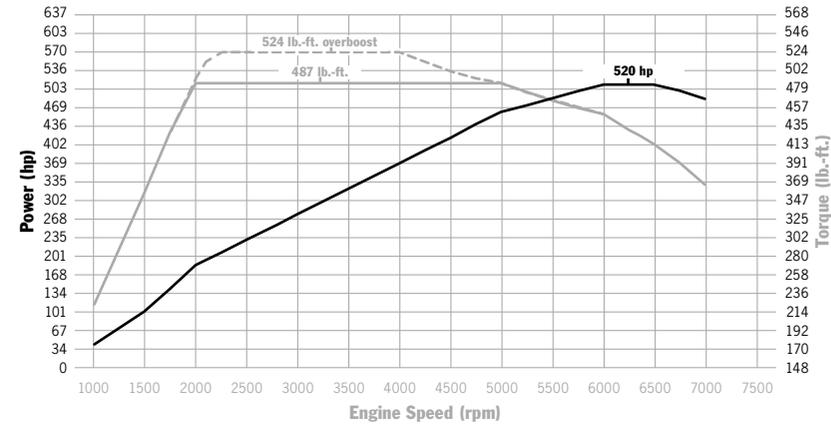

911 Turbo and 911 Turbo Cabriolet:
487 lb.-ft. between 1950 and 5000 rpm, 520 horsepower between 6000 and 6500 rpm

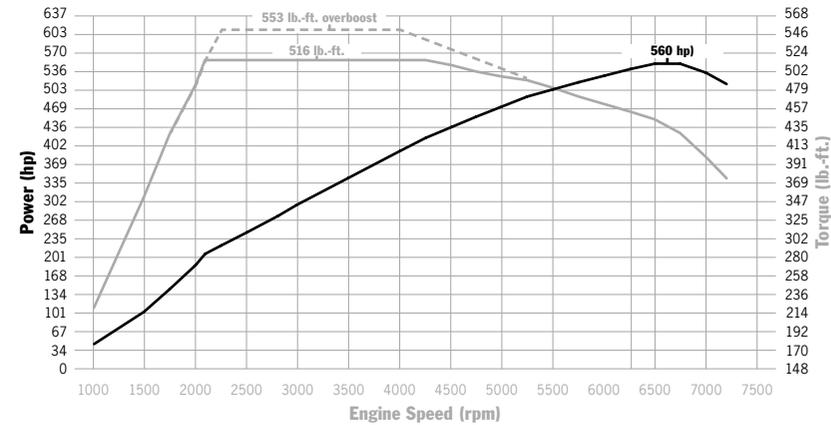

911 Turbo S and 911 Turbo S Cabriolet:
516 lb.-ft. between 2100 and 4250 rpm, 560 horsepower between 6500 and 6750 rpm



The 3.8-liter, 6-cylinder boxer engine is made with a lightweight alloy design. The engine's impressive power-to-weight ratio increases agility and optimizes fuel efficiency.

The connecting rods and aluminum pistons are forged for added strength, and each piston is individually cooled by oil injection nozzles in each cylinder. The cylinders

are made from an aluminum alloy that offers exceptional resistance to the punishing heat generated by a high-performance engine.

The result—for you, and for the 911 Turbo driving experience—is an engine with extraordinary power and surprisingly low consumption, especially when compared to engines with greater displacement.

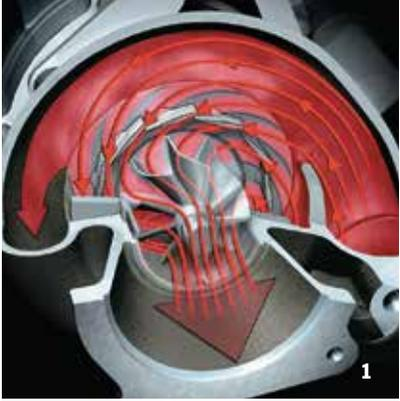

1

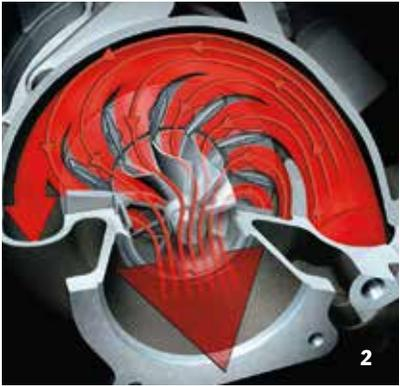

2

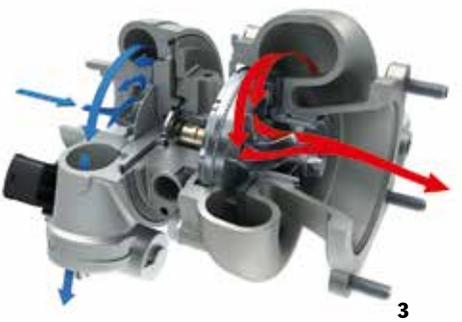

3

Variable Turbine Geometry (VTG)
 One of the critical factors in designing a turbocharged engine has always been the size of the turbo units. Large turbines create massive boost, but suffer “turbo lag” as they begin to spool up. Smaller turbines respond more quickly, but lack the capacity to induce large amounts of exhaust air. With Variable Turbine Geometry (VTG), Porsche engineers have resolved this conflict. As exhaust flow from the engine is channeled into the turbines, the engine management system controls the electronically adjustable guide vanes, changing the vane angle so the system can replicate the advantages of both sizes of turbo, large and small. The optimal gas-flow characteristics are achieved at all times.

This results in a high turbine speed—and greater boost pressure—even at low engine rpm. With more air available, the combustion is increased, yielding better power and torque. The torque curve reaches its maximum level much sooner—and stays there. VTG also improves the response of the turbo engine with dynamic boost pressure development.

When the boost pressure reaches its maximum value, the guide vanes are opened further. By varying the vane angle, it is possible to achieve the required boost pressure over the entire engine-speed range, so excess pressure valves are no longer required.

1 Vanes closed | 2 Vanes open | 3 Variable Turbine Geometry (VTG)

Porsche revolutionized the modern sports car with the original 911 Turbo. And with innovations such as Variable Turbine Geometry (VTG) in the new 911 Turbo, the revolution carries on.

VarioCam Plus
 VarioCam Plus is a two-in-one engine concept that adjusts the camshafts on the intake side and controls valve lift.

The system distinguishes between normal everyday driving and maximum power requirements and adapts to the corresponding conditions. The switchover is performed imperceptibly by the electronic engine management system. The result is spontaneous acceleration, an extremely quiet drive, and extraordinary engine power with comparatively low fuel consumption.

Expansion Intake Manifold
 More power using less fuel. Sounds paradoxical, but it's really quite simple. You just have to question the norm.

Take the intake manifold in the new 911 Turbo models, as an example. With a traditional resonance manifold, more air means more power. The compression effect in the intake system is used to

press as much of the air/fuel mixture as possible into the cylinders. But added compression not only increases air volume—it also raises air temperature. And this has a negative effect on ignition.

The 911 Turbo model's expansion manifold turns that principle around. The internal geometry is radically different from that of a resonance intake system. Key modifications include a longer distributor pipe with a smaller diameter, and shorter intake pipes. As a result, the air is in the expansion phase as it enters the combustion chambers.

Since expansion always cools, the air/fuel temperature is lower, ignition is significantly improved, and—here's the best part—performance is increased.

The amount of air that enters the engine under expansion is less than it would be under compression. To compensate for this, Porsche engineers simply increased the boost pressure. The resulting increase in temperature—again through compression—is immediately offset by the uprated intercoolers.

Instead of hot compressed air entering the combustion chambers, the cooler air generates more power and torque. As a consequence, there is a major improvement in engine efficiency. Fuel consumption is lower, even under heavy loads and at high revs.



4 VarioCam Plus

4

Thermal Management

The thermal management system regulates the temperature in the engine and transmission through the intelligent manipulation of heat flow. It allows the engine and transmission to reach their optimal operating temperatures sooner. The result? Combustion efficiency and lubrication performance are improved, and fuel consumption is reduced.

Auto Start Stop Function

The Auto Start Stop function is standard in the new 911 Turbo models. When the speed falls below 4 mph and the 911 Turbo is decelerating normally, the engine switches off. For example, as you are slowing while approaching a red light.

Audio and communication systems remain switched on. The climate control continues to maintain your selected temperature. The engine starts again when you release the brake or move the steering wheel.

The Auto Start Stop function may remain inactive under particular circumstances, for example if the battery charge is low, when the Sport button is selected, or when there are extreme outside temperatures. It is also possible to deactivate the function manually using a separate button on the center console.

Electrical System Recuperation

Another fuel-saving innovation that's standard on the new 911 Turbo models is electrical system recuperation technology. It captures the energy created during events such as braking. The vehicle battery is recharged by the alternator, predominantly under braking. Under acceleration, on the other hand, the power draw of the alternator is limited to increase the engine output available for driving. The electrical systems are supplied by the electrical energy stored during the recharging process.





To make something happen, you have to be able to convey your principles.

Transmission.

Porsche Doppelkupplung (PDK)

All of the new 911 Turbo models feature the enhanced PDK transmission with manual and automatic modes. Porsche engineers have yet again increased the speed and smoothness of gear shifts. For the driver, this means even faster shifting through the gears without interrupting

the flow of power. Acceleration is exceptional, fuel consumption is optimized, and performance is delivered at a high level of comfort.

PDK has seven gears at its disposal. Gears 1 through 6 have a sport ratio and top speed is reached in 6th gear.

The 7th gear has a long ratio and helps to reduce fuel consumption by keeping engine revs low.

PDK is essentially two transmissions in one. This double-clutch arrangement provides an alternating, non-positive connection between the two half

gearboxes and the engine by means of two separate input shafts.

The flow of power from the engine is transmitted through one half gearbox and one clutch at a time, while the next gear is preselected in the second half gearbox. During a gear change,



one clutch simply opens and the other closes at the same time, enabling shifts to take place within milliseconds.

Depending on the gearshift program (Sport button activated or deactivated), the shift of gears is optimized for comfort or for sporty driving.

With the optional Sport Chrono Package (standard in the 911 Turbo S models), PDK is enhanced by the Launch Control and motorsport-derived gearshift strategy functions.

1 Power transmission in 1st gear

Coasting

The coasting function enables you to save even more fuel when the situation allows. In coast mode, the engine is decoupled from the transmission to prevent deceleration caused by engine braking. Optimal use is made of the vehicle's momentum, allowing the 911 Turbo to seamlessly coast at certain times while consuming significantly less fuel.

It works like this: Say, for example, you want to slow down from 65 mph to 55 mph in anticipation of the change of speed limit ahead. As soon as you release the accelerator pedal, PDK

deselects the current gear automatically and you begin to coast in Neutral until you have reached your desired speed. The moment you engage the accelerator or brake pedal, PDK selects the appropriate gear smoothly and seamlessly within a fraction of a second.

Another way the coast function helps reduce fuel consumption is when you're driving downhill. If the gradient is gentle enough for you to maintain a constant speed, the transmission decouples the drive power to save fuel. Yet PDK remains ready to respond as swiftly and precisely as you would expect.

In short, driving in coasting mode makes a real impact on fuel consumption without any need for compromise on comfort or sporty performance.



Porsche Traction Management (PTM)

Enhanced Porsche Traction Management (PTM) with water-cooled front-axle gearbox is standard in all of the new 911 Turbo models. It is an active all-wheel-drive system with an electronically variable map-controlled multiplate clutch, Automatic Brake Differential (ABD), and Anti-Slip Regulation (ASR).

And it delivers the high power of the new 911 Turbo models even more effectively and efficiently to the road. This is thanks to the new water-cooling system for the front-axle gearbox. Water conducts heat better than air. So the cooling jackets

placed on the gearbox have several advantages: When you first start your 911 Turbo, the water ensures that the gearbox warms up more quickly—and reaches its optimal temperature sooner.

And during the drive itself, the heat produced is dissipated more easily. So more torque and more drive force can be transmitted through the gearbox to the front axle.

Drive power is distributed between the permanently driven rear axle and the front axle by means of the electronically variable multiplate clutch.

The status of the vehicle is continuously monitored so that it is possible to respond to different driving situations. Sensors are used to collect a range of data, including the rotational speed of all four wheels, the lateral and longitudinal acceleration of the car, and the current steering angle.

If, for example, the rear wheels begin to lose traction under acceleration, a greater proportion of the drive power is automatically transmitted to the front axle by a more positive engagement of the multiplate clutch. In addition, ASR prevents wheelspin by adapting the engine's power output. During cornering,

the optimal level of drive power is distributed to the front wheels to help ensure excellent lateral stability.

In conjunction with Porsche Stability Management (PSM), PTM helps to ensure the perfect distribution of drive power for optimal traction in most road scenarios, whether on long straights, through tight corners, or on surfaces with different friction coefficients.



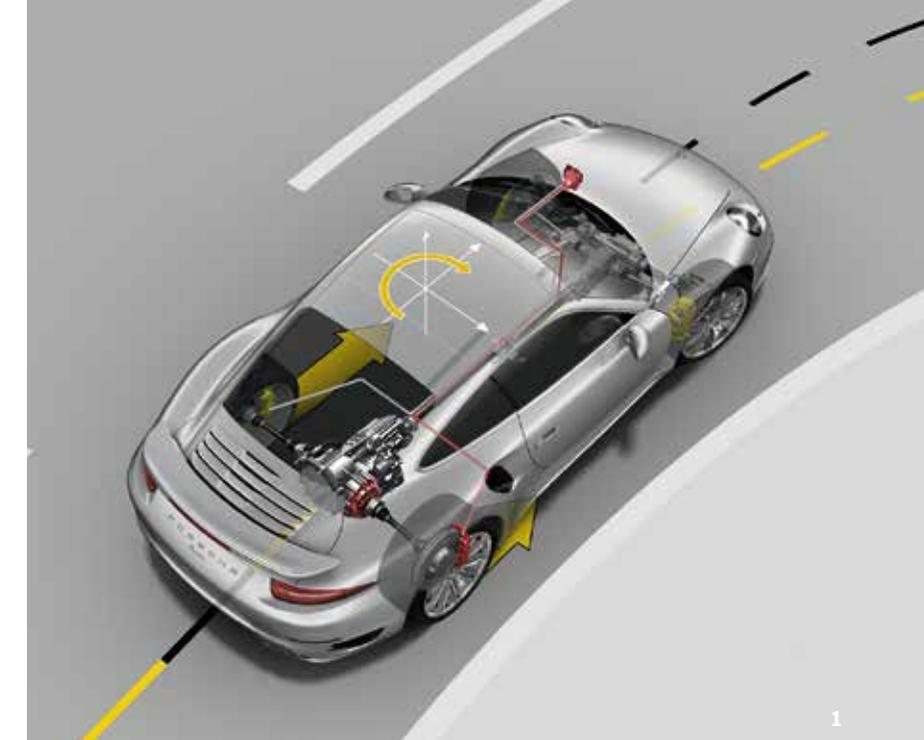

Porsche Torque Vectoring Plus (PTV Plus) Including Electronic Rear Differential Lock

PTV Plus is standard on all new 911 Turbo models: The system actively enhances vehicle dynamics and stability and operates, in conjunction with an electronic rear differential

lock, by varying the distribution of torque applied to the rear wheels.

By constantly monitoring steering angle and steering speed, accelerator pedal position, yaw rate, and vehicle speed, PTV Plus is able to improve steering response and steering

precision by specific braking of the right or left rear wheel.

Here's how it works: When the 911 Turbo is driven assertively into a corner, moderate brake pressure is automatically applied to the inside rear wheel. Comparatively, the outside rear wheel receives a greater amount

of drive force distribution, inducing an additional rotational pulse (yaw movement) around the vehicle's vertical axis. This results in a direct and sporty steering response as the 911 Turbo enters the corner.

At low and medium vehicle speeds, PTV Plus significantly increases agility and steering precision. At high speeds and when accelerating out of corners, the rear differential lock, with infinitely variable torque distribution, ensures greater driving stability.

The system thus interacts with Porsche Stability Management (PSM) to improve driving stability on a range of surface conditions, including water and snow.

What does all this mean for the 911 Turbo driver? Outstanding traction, as well as greater agility at every speed with precise steering and stable load transfer characteristics. In other words, unrivaled driving pleasure at every twist and turn.

1 Porsche Torque Vectoring Plus (PTV Plus)

Sport Button

Standard on all new 911 Turbo models, the Sport button enables you to select a suspension setup to emphasize either comfort or sporty performance. At the push of a button, the electronic engine management system switches the engine mapping to offer an even sharper response. In conjunction with the Sport Chrono Package (standard in the 911 Turbo S and the new 911 Turbo S Cabriolet), the overboost function is then active and the dynamic engine mounts become much firmer.

In Sport mode, PDK ensures that upshifts take place at higher engine speeds and downshifts happen sooner. Coasting mode and the Auto Start Stop function are deactivated.

Sport Chrono Package Including Dynamic Engine Mounts

The Sport Chrono Package including dynamic engine mounts is standard in the 911 Turbo S models and available as an option for the new 911 Turbo. This integrated system provides simultaneous enhancement for the chassis, including rear-axle steering, engine, transmission, and aerodynamics.

The main features include a digital and analog stopwatch mounted on the dashboard, a performance display in the Porsche Communication Management (PCM) system, the Sport Plus button, and the overboost function.

Activate Sport Plus mode and here's what happens: Porsche Active Suspension Management (PASM), the electronic suspension management, becomes more

responsive. PASM and Porsche Dynamic Chassis Control (PDCC)—standard in the new 911 Turbo S—switch to Sport Plus mode for a firmer suspension setting, more direct steering while cornering, and increased roll stabilization. The rear-axle steering also reacts more directly—for even more agile steering. As part of Porsche Active Aerodynamics (PAA), the automatic adjustment of the front and rear spoilers is also impacted in the performance setting in Sport Plus mode. So you can make full use of the performance potential of your 911 Turbo.

In Sport Plus mode, the trigger threshold for PSM is raised. Agility is perceptibly enhanced when braking for corners with PSM, allowing sportier braking and exit acceleration. For maximum dexterity, PSM can be set to standby while the car is still in Sport Plus mode. Although, for safety, it's still there in the background.

With the Sport or Sport Plus button active, under full acceleration, the maximum boost pressure in the lower and medium speed ranges is now temporarily increased by approximately 2 psi: the overboost. Engine torque is also boosted by 37 lb.-ft. for a short time—to 524 lb.-ft. in the 911 Turbo and the 911 Turbo Cabriolet. In the 911 Turbo S models, it goes up to 553 lb.-ft.

The Sport Chrono Package has two additional functions. The first is Launch Control, which helps achieve optimal acceleration from a standing start. The second function is the motorsport-derived gearshift strategy. Using this, PDK optimizes shift times for maximum acceleration.



1 Digital and analog stopwatch mounted on the dashboard | 2 Sport buttons in the center console | 3 Steering wheel display with PDK and Sport Chrono Package



Dynamic Engine Mounts

Engineers traditionally face a conflict when designing the engine mounts of a performance car. A hard engine mounting delivers optimal performance by offering a higher degree of handling

precision. Soft engine mounts, on the other hand, minimize oscillations and vibrations. Comfort is improved on uneven road surfaces, but at the expense of razor-sharp performance.

With the dynamic engine mounts that are part of the Sport Chrono Package, Porsche engineers have resolved this inherent conflict. The mounts contain a fluid with magnetic properties that interact

with an electrically generated field. Depending on the driving style and road surface conditions, the electronically controlled system automatically adjusts the stiffness and damping properties of the engine mounts.

When the driving style is assertive, the mounts become “hard,” and handling is perceptibly more stable under load change conditions and in fast corners. Whenever a less assertive driving style is adopted, the dynamic engine mounts

“soften” to provide a more comfortable feel. The dynamic mounts minimize the oscillations and vibrations of the entire drivetrain, especially the engine.

For the driver, the results are tangible. A harder-edge handling response when you demand it, a more comfortable ride when you don't.

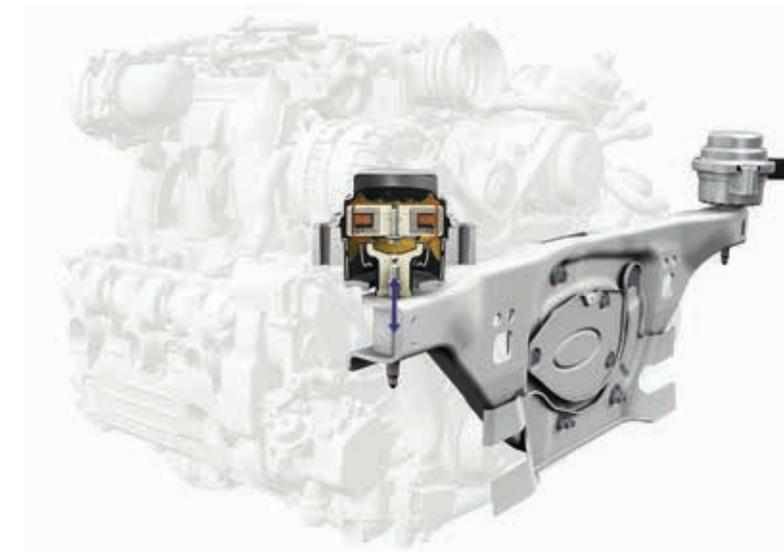

1

1 Dynamic engine mounts

Longer and wider, it still gets to the point in the shortest amount of time possible.

Chassis.

The chassis on the new 911 Turbo features a longer wheelbase and an even wider track. But make no mistake: The 911 Turbo is still about shortening distances: between entry and exit, between one city and the next, between you and driving pleasure.

Changes to the chassis dimensions on the new 911 Turbo enable smoother high-speed maneuvers and exceptionally high levels of stability. Its cornering agility can scarcely be described in words.

The new rear-axle steering transforms the cornering feel of the new 911 Turbo. Handling is much more responsive at low speeds. And at higher speeds, stability is increased.

Other contributions to the 911 Turbo driving experience are made by its chassis control systems: Porsche Stability Management (PSM), Porsche Active Suspension Management (PASM), and Porsche Dynamic Chassis Control

(PDCC), which is standard in the new 911 Turbo S models and available as an option for the 911 Turbo and the new 911 Turbo Cabriolet.

Each of these systems is detailed in the following pages. For now, all you need to know is: Longer and wider is a good thing.



Rear-Axle Steering

Porsche engineers have always factored in the positive effect of passive rear-wheel steering—the slight articulation of the rear wheels to “toe in” or “toe out” when cornering. Thanks to the new rear-axle steering that’s standard on all new 911 Turbo models, that effect is no longer passive. Two electromechanical actuators located on the rear axle steer the rear wheels of the new 911 Turbo models up to approximately 2.8 degrees in the same or opposite direction as the steering angle on the front axle, depending on speed.

At speeds of up to 31 mph, the system steers the rear wheels in the opposite direction to that of the front wheels.

This has the virtual effect of shortening the wheelbase. The turning circle is reduced, steering into corners becomes much more dynamic, and parking is noticeably easier.

At speeds above 50 mph, the system steers the rear wheels in the same direction as that of the front wheels. The effect is a virtual extension of the wheelbase for increased stability during high-speed maneuvers—a cruising-speed lane change on the interstate, for example.

Between 31 and 50 mph, the steering direction is constantly changing, depending on the driving conditions. Thanks to the excellent stabilizing properties of rear-axle steering, it has also been possible to make the steering ratio on the front axle more direct around the central position. The advantage is greater agility at higher speeds.

There is no contradiction between stability and agility, performance, and everyday practicality. The new rear-axle steering results in greater maneuverability in day-to-day driving—and a clearly noticeable increase in maximum performance.



1



2

1 More agile effect of rear-axle steering | 2 Stabilizing effect of rear-axle steering



1

Porsche Active Suspension Management (PASM)

Included as standard equipment, Porsche Active Suspension Management (PASM) is an electronic active damping system.

It offers continuous adjustment of the shock absorber's damping force on each wheel, based on current road conditions and driving style.

At the press of a button, the driver can choose between two modes. Normal mode provides a blend of performance and comfort. Sport mode has a much firmer range of settings. The system responds to changing road conditions

and/or driving style by continuously varying the individual damping forces within the parameters defined for the selected setup mode, Normal or Sport. Pitch and roll are reduced, while the contact of each wheel with the road is optimized.



2

The New 20-Inch 911 Turbo Wheel

On the 911 Turbo and the 911 Turbo Cabriolet, new 20-inch 911 Turbo wheels are standard. The large wheel size improves contact with the road, and the wheels are forged aluminum to reduce weight and unsprung masses.

The new 911 Turbo wheels are one inch larger than those on the predecessor. The exact specification is 8.5J x 20 wheels at the front combined with 245/35 ZR 20 tires. At the rear are 11J x 20 wheels with 305/30 ZR 20 tires.

The New 20-Inch 911 Turbo S Wheel with Central Locking Device

These forged aluminum wheels painted in black with a polished finish are available as an option for the new 911 Turbo models and are standard on the 911 Turbo S models. They are especially light and are setting standards in driving comfort and performance—as well as in design. With central locking device including chrome-plated trim with colored Porsche Crest.

There are 9J x 20 wheels on the front fitted with 245/35 ZR 20 tires and 11.5J x 20 wheels at the rear with 305/30 ZR 20 tires.

A focal point is the anodized black central locking devices. Derived from Porsche's motorsport experience, they deliver an even-more agile driving experience by reducing rotating masses.

Tire Pressure Monitoring System (TPMS)

Tire Pressure Monitoring System (TPMS) is included as standard equipment in all models. It warns against low tire pressure or slow or sudden pressure loss. The driver is informed via the onboard computer display. And the pressures of all four tires can be checked at any time from the instrument cluster.

1 20-inch 911 Turbo wheel | 2 20-inch 911 Turbo S wheel with central locking device

Porsche Stability Management (PSM)

All new 911 Turbo models come with enhanced Porsche Stability Management (PSM). It helps maintain stability even at the limits of dynamic driving performance. Sensors continuously monitor the direction, speed, yaw velocity, and lateral acceleration of the car. Using this information, PSM is able to calculate the actual direction of travel at any given moment. If the car begins to oversteer or understeer, PSM applies selective braking on individual wheels to help restore stability.

Under acceleration on wet or low-grip road surfaces, PSM improves traction using the Automatic Brake Differential (ABD) and Anti-Slip Regulation (ASR). When the Sport Plus mode of the Sport Chrono Package is selected, the PSM threshold is raised to allow a more assertive driving style.

PSM can be deactivated. But for your safety, it is automatically reactivated only if you brake hard enough that either of the front wheels (in Sport Plus mode, both of the front wheels) requires ABS (Anti-lock Brake System) assistance. ABS and ABD, however, remain active at all times.

Porsche Dynamic Chassis Control (PDCC)

Porsche Dynamic Chassis Control (PDCC) is standard on 911 Turbo S models and available as an option on 911 Turbo models. PDCC is an active anti-roll system that suppresses lateral body movement during cornering maneuvers and helps minimize the lateral instability of the vehicle on uneven ground. The result is a car with improved roadholding and more dynamic performance.

PDCC optimizes camber using hydraulic stabilizing actuators in the form of cylinders. Lateral roll is counteracted by forces generated at each individual wheel, based on steering angle and lateral acceleration.

How does this translate to the driving experience? More dynamic performance with optimized turn-in and stable load transfer characteristics. And increased ride comfort.



1 Fast cornering with the 911 Turbo without PDCC (illustration) | 2 Fast cornering with the 911 Turbo S with PDCC (illustration)



1



2



3



4



5



6

Porsche Active Aerodynamics (PAA)

For the first time in a Porsche road car, the new 911 Turbo models use active aerodynamics. Derived from similar systems used on Porsche race cars, the new Porsche Active Aerodynamics (PAA) meets two critical objectives: to make the drag coefficient as low as possible, and to set a new standard for downforce.

PAA is a combination of multistage adjustable front and rear spoilers. The front spoiler—which is made from a flexible, pneumatic elastomer—and the rear spoiler will extend and retract synchronously in three positions.

In Stage 1 (Start), the front and rear spoilers are completely retracted. It's intended for everyday use—there's

less risk of getting the front spoiler caught on ramps, speed bumps, or curbs. The spoiler lip is well-protected.

In Stage 2 (Speed), after 74 mph, the front and rear spoilers are partially extended. This ensures a high level of stability and a low drag coefficient.

Stage 3 (Performance) is activated by the press of a button, with the spoiler button or—in conjunction with the Sport Chrono Package—the Sport Plus button.

The front and rear spoilers are now completely extended. The “turbo” or “turbo S” logo can be seen on the front spoiler lip. Also, in Stage 3, the rear spoiler is tilted by up to

15 degrees. Thanks to the high level of downforce on the front and rear axles, in this setting the new 911 Turbo can release its full performance potential—for example, on the racetrack. The downforce also provides advantages when braking at high speeds.

Porsche Active Aerodynamics (PAA). A system that combines everyday use, efficiency, and driving performance. And reaches its objectives in the 911 Turbo way.

1 Rear spoiler in Start position | 2 Front spoiler in Start position | 3 Rear spoiler in Speed position | 4 Front spoiler in Speed position | 5 Rear spoiler in Performance position | 6 Front spoiler in Performance position



1



2



1



2

Pedal distance. Braking distance. Distance home.
Our engineers are focused on your racing line.

Lighting.

Bi-Xenon™ Headlights with PDLs

The 911 Turbo models come standard with Bi-Xenon™ headlights including a headlight-cleaning system and dynamic range control—for an even illumination of the road ahead.

Also standard: the Porsche Dynamic Light System (PDLs). This dynamic cornering light function swivels the main headlights toward the inside of a corner, for better illumination and a faster response. LED technology is also used for the front lights, taillights, the high-level

third brake light, the license plate illumination, the rear direction indicators, and the rear fog light.

The LED front units incorporate direction indicators, daytime running lights, and position lights.

The lighting system features an automatic switch-off and the “Welcome Home” function.

LED Headlights Incorporating Porsche Dynamic Light System Plus (PDLs Plus)

A new development, LED headlights incorporating Porsche Dynamic Light System Plus (PDLs Plus), are standard on the 911 Turbo S and the new 911 Turbo S Cabriolet and available as an option for the 911 Turbo models. The inner workings of each headlight consist of two housings arranged at different levels—and certainly make an impression.

The bright LED light improves illumination of the road ahead. Thanks to optimized near-side and distance lights and the daylight-like coloring and reduced scatter

of the light, the driver’s eyes become tired less quickly than with other systems.

Porsche Dynamic Light System Plus (PDLs Plus) is combined with the LED headlights. In addition to all of the functions provided by PDLs, PDLs Plus also has High Beam Assistant.

Lighting

The front light units of the 911 Turbo models incorporate LED direction indicators and position lights. Automatic headlight activation is also included as standard. The moment it gets dark, the dipped headlights switch on automatically.

In the 911 Turbo and 911 Turbo Cabriolet, the daytime running lights are arranged horizontally in the front light units. In the 911 Turbo S models, daytime running lights take the form of four spotlights located in the headlight.

1 911 Turbo with Bi-Xenon™ headlights with PDLs | 2 911 Turbo S with LED headlights incorporating PDLs Plus



Responsibility.

With great power comes great responsibility. To yourself, and to your passengers. To those who share the road. To future generations and the environment. At Porsche, we believe the actions we take must reflect those responsibilities. And that our cars must turn engineering challenges into opportunities, so Porsche and Porsche drivers can contribute to a safer, more sustainable world.





A performance isn't finished until it comes to a complete stop.

Brakes.

Why has Porsche always viewed braking performance with the same enthusiasm we share for our engines and chassis? Perhaps it is because we think of braking as negative acceleration. For us, braking response and the stopping distances achieved by the new 911 Turbo models should be every bit as breathtaking as our throttle response and acceleration times. A Porsche 911 Turbo model's goal is nothing less than to be the new reference point for sports car braking. The braking performance must provide the driver ample reassurance that when speed needs to be shed, the brakes will respond accordingly.

In the new 911 Turbo and the new 911 Turbo Cabriolet, the brake specification is suited to the demands of high performance. The brake disc diameter is 380 mm front and rear. Grabbing hold of the front discs are powerful 6-piston, aluminum monobloc fixed calipers finished in red. At the rear, 4-piston, aluminum monobloc fixed calipers press the pads to the disc.

The brake calipers have an enclosed monobloc construction. This makes them tougher but lighter and enables a more rapid response and release of the brake, even under extreme loads. The pedal travel is short and the biting point precise.

The brake discs are cross-drilled for better performance in wet conditions.

Other benefits of the braking system include the Anti-lock Brake System (ABS), designed to minimize brake fade and keep braking response constant. Pedal effort is reduced and braking response improved by a tandem vacuum brake booster. Brake-disc cooling is optimized by air spoilers.

Electric Parking Brake

The electric parking brake, which you can activate and deactivate manually, releases automatically as you pull away.



With the hill-hold function, you can pull away without ever rolling back. The system automatically detects when the vehicle has come to a halt on an uphill gradient, requiring intervention. PSM then maintains the brake pressure at all four wheels to prevent the vehicle from moving in the opposite direction.

1 Standard brakes in the 911 Turbo



Porsche Ceramic Composite Brakes (PCCB)

How exactly does Porsche take its motorsport experience and transfer it from the racetrack to the road? The Porsche Ceramic Composite Brakes (PCCB) are a clear example. Standard equipment in the 911 Turbo S models and available as an option for the 911 Turbo models, PCCB has already had to cope with the harsh requirements of motor racing and is fitted in race cars that compete in demanding events such as the Porsche Mobil 1 Supercup.

The cross-drilled PCCB ceramic brake discs have a diameter of 410 mm at the

front and 390 mm at the back—for even more formidable braking performance.

The use of 6-piston, aluminum monobloc fixed calipers on the front axle and 4-piston, aluminum monobloc units at the rear—all finished in yellow—ensures extremely high brake forces that remain exceptionally consistent.

PCCB enables shorter braking distances in even the toughest road and track conditions. Excellent fade resistance guarantees greater balance when slowing from highway speeds.

The key advantage of PCCB is the extremely low weight of the ceramic brake discs. Approximately 50 percent

lighter than standard discs of similar design and size, they enhance performance and fuel economy. Because this represents a major reduction in unsprung and rotating masses, it yields many results: better roadholding and increased comfort, particularly on uneven roads, as well as greater agility and improved handling.



1 Porsche Ceramic Composite Brake (PCCB)



Body

The innovative bodyshell of the new 911 Turbo models fulfills two structural design requirements: first, excellent driving dynamics due to the body's extremely high rigidity. Second, a savings in vehicle weight, primarily due to its intelligent lightweight construction.

To meet the second requirement, we employed state-of-the-art techniques for combining various materials in order to utilize specific material properties exactly where they are needed.

Take the bodyshell, for example. It uses very thin—but extremely rigid—sheets of steel. Aluminum and magnesium were utilized extensively in areas including the roof, underbody, doors, engine compartment, and luggage

compartment lids. Magnesium, which is a particularly lightweight material, was also selected for the cockpit and center console support beam. Reducing the overall weight—i.e., improving the power-to-weight ratio—translates directly into the aim of increasing performance, whether that's measured by the acceleration, steering, or braking. And it's measurable another way, too: at the fuel pump. Reduced fuel consumption.

For the driver, reducing the weight of the 911 Turbo results in a high level of comfort as well. Vibration-damping characteristics are excellent and, compared to the previous model, torsional stiffness has increased up to 25 percent to create even sportier handling.

Airbags and the Porsche Side Impact Protection (POSIP) System

The airbag technology in the new 911 Turbo models provides full-size driver and front-passenger airbags, which are inflated in two stages depending on the severity and type of accident. In less serious accidents, the airbags are only partially inflated to help minimize discomfort to the occupants.

Another standard feature is the Porsche Side Impact Protection (POSIP) system. This system comprises side impact protection elements in the doors and two airbags on each side, an integral thorax airbag located in each seat side bolster, and a head airbag contained in each of the door panels. Knee airbags are also standard on all 911 Turbo models.

Rollover Protection in the Cabriolet Models

Despite their light weight, the 911 Turbo Cabriolet models have exemplary torsional rigidity and flexural strength. Body flexing is minimal, especially when compared with driving most other open-top sports cars on uneven road surfaces.

In the event of a 911 Turbo Cabriolet model rolling over, additional protection is provided by a supplemental safety roll bar protection system that deploys automatically. The two spring-loaded rollover bars are located behind the back seats. The rollover sensor continuously monitors the car's pitch and roll, lateral and longitudinal acceleration, and contact with the road. In an emergency, it deploys the rollover bars within a fraction of a second.

What we find when we go our own way: solutions.

Environment.

All automotive manufacturers look to the future. After all, the life-span of an automobile from inception to the end of its functional life can span decades or even longer. So what the world needs in 15 to 20 years, Porsche engineers must address now. Our focus is always on this: ultimate performance with ultimate efficiency.

Porsche has increased efficiency in all of its current series while at the same time increasing performance. This is achieved by an efficient drive, thanks to Direct Fuel Injection (DFI), Porsche Doppelkupplung (PDK), Variable Turbine Geometry (VTG) and VarioCam Plus, intelligent lightweight construction, active aerodynamics, and low rolling resistance.

A high level of environmental responsibility is ensured not least by Porsche's own environmental management teams in Weissach. They ensure that all developments take account of environmental compatibility. The objective is to achieve pure performance, but not at the expense of the environment. This also applies to the new 911 Turbo models.



Exhaust Emissions Control

At Porsche, our cars have long demonstrated that even high-performance sports cars can achieve moderate fuel consumption and exhaust emissions values in their respective category.

The new 911 Turbo is no exception. It uses technologies such as Auto Start Stop, thermal management, electrical system recuperation, Direct Fuel Injection (DFI), VarioCam Plus, and coasting to help optimize fuel efficiency.

And the catalytic converters provide efficient emissions control.

The stereo lambda sensor controls and monitors each cylinder bank separately. For each exhaust tract,

oxygen sensors regulate the composition of the exhaust gas, while another lambda sensor on each cylinder bank monitors pollutant conversion in the respective catalytic converter.



Recycling

For both technical and ecological reasons, intelligent lightweight construction has been fundamental to Porsche since our first car in 1948. This forms the basis for achieving low fuel consumption values in conjunction with outstanding performance.

On the technical side, we use a high proportion of aluminum, magnesium, plastics, and super high-strength sheet steel. The materials used have been selected for their ability to withstand load, yet they are considerably lighter than conventional steel.

On the ecological side, all materials used are meticulously selected. All synthetic components are easily recyclable. And each material is labeled to facilitate its separation for recycling. The reduction in the number of plastic variants helps to ensure more efficient recycling. Recycled plastics are used where they meet our exacting technical requirements.

In short, the new 911 Turbo models are approximately 95 percent recyclable.

In addition, Porsche uses a high proportion of environmentally friendly water-based paints. For us, environmental protection does not begin at the end of a vehicle's life. It starts at the planning and development stage.

Fuel

All Porsche models are designed to operate on fuels with an ethanol content of up to 10 percent. Ethanol has a positive impact on the CO₂ balance since the plants grown for the production of this biofuel also absorb CO₂ from the atmosphere.

The release of hydrocarbons from the fuel system has been minimized, thanks in no small part to the active carbon filter and the multilayered material from which the fuel tank is made. All fuel lines are made from multilayered plastic, steel, or aluminum.

The new 911 Turbo models have maximized the fuel-saving technologies, which results in all the 911 Turbo models

having the same fuel economy of 17 mpg in the city and 24 mpg on the highway.

Noise

The 911 Turbo models and the new 911 Turbo S comply with all current noise regulations—without resorting to engine encapsulation. To achieve this, we've eliminated noise at the source: Engine components are more rigid, moving parts lighter, and tolerances reduced to a minimum. High-efficiency silencers and resonators in the intake system help to reduce noise even further.



Personality.

Porsche engineers have given the new 911 Turbo its essential character. But there's ample opportunity for Porsche owners to further define the personality of their new 911. From the exterior color choice to a wide range of features that individualize the interior, you can make the model you select a precise expression of your personality.





**Inside, yet another Porsche extreme:
extreme quiet.**

Comfort.

With the new 911 Turbo models, our engineers have pushed forward into the extreme performance range. The fact that the driver can remain quite composed is also due to the answers they have found to the questions about sportiness, ergonomics, and comfort.

Interior

A Porsche interior is never frivolous, always direct. In the new 911 Turbo, clever technology and clear operating logic allow the driver to experience all that makes this the benchmark for Porsche performance, as evident at once from the ascending center console. In

typical Porsche fashion, the use of form follows a basic principle: Focus on the driver. It's why the distance between the gear selector and steering wheel is extremely short, and the operating logic of systems such as the dual-zone air conditioning or the suspension is clear and uncomplicated. You shouldn't have to browse one submenu after another. You should instead be able to concentrate on what's singularly important: the road.

Materials of high quality define the sporty character of each 911 Turbo model. The standard Leather package includes

Leather seats, dashboard, and door and side trims. Alcantara® has proven its worth in motorsport and is now standard for the roof liner on the Coupe models. The exclusive two-tone interior in Black and Carrera Red is reserved especially for the 911 Turbo S models. Dashboard, center console, and door panel trim strips in Carbon are standard in these models (available as an option for the 911 Turbo and 911 Turbo Cabriolet).

In addition to the choice of Black, Platinum Grey, Luxor Beige, and Yachting Blue for the interior, there is a wide range of other personalization options available,

including two-tone color combinations or special colors and materials such as Carbon, Aluminum, or high-quality Wood.

Engineering that takes you forward: the Porsche Communication Management (PCM) system with navigation module and a high-resolution 7-inch color touchscreen. PCM is your control center for audio, navigation, and communication functions. It's fitted as standard in the new 911 Turbo models.

1 911 Turbo interior in Espresso



1

Another way of setting standards: sound. The new 911 Turbo comes standard with the Bose® Surround Sound System. Its total power output of 445 watts provides outstanding performance.

The High-End Surround Sound System from Burmester® is available as an option. Burmester® is one of the most respected premium audio manufacturers

1 Burmester® High-End Surround Sound System | 2 SportDesign steering wheel



2

SportDesign Steering Wheel

The SportDesign steering wheel is a standard feature of the 911 Turbo models. It is adjustable for both height (by up to 1.5 inches) and reach (up to 2.25 inches) and, thanks to its grip moldings, it's in safe hands—even on the sportiest of drives. The steering wheel features two gearshift paddles made from a strong alloy. They are ergonomically located behind the left-

and right-hand steering wheel spokes. Pull the right-hand paddle and PDK shifts up. Pull the left-hand paddle and PDK shifts down. Combined with the optional Sport Chrono Package (standard in the 911 Turbo S and the new 911 Turbo S Cabriolet), the left- and right-hand spokes also include a display that tells you whether



3

the Sport, Sport Plus, and Launch Control functions are activated.

As an option, for no extra charge, you can have a sport steering wheel with multifunction buttons.

3 911 Turbo instruments | 4 SportDesign steering wheel with gearshift paddles

Instruments

The five round instruments have one purpose above all: to provide information efficiently and accurately. The five-gauge cluster is a signature of Porsche design and, as always, the large tachometer is in the middle.

The 4.6-inch, high-resolution TFT color screen provides you with a continuous stream of data from the onboard computer, such as trip mileage or average fuel consumption. It also displays the navigation system map, delivers various warnings, including



4

alerts from the Tire Pressure Monitoring System (TPMS), and reminds you of your selected communication and audio settings. You can also use it to carry out individual vehicle settings.

Power Sport Seats

When it comes to seating, the goals of high performance are typically at odds with the desire for comfort. But the seats in the new 911 Turbo manage to serve both goals equally well. The Sport seats that are standard in the new 911 Turbo and the new 911 Turbo Cabriolet offer full power adjustment of seat height, backrest angle, seat cushion angle, and seat cushion depth, as well as fore/aft position, and four-way lumbar support.

The integrated memory package supports the exterior mirrors and all seat positions on the driver's side as well as settings for the steering wheel, lights, wipers, air conditioning, door locks, PCM, and instrument cluster.

Adaptive Sport Seats Plus

For maximum sports performance, Adaptive Sport Seats Plus are standard in the new 911 Turbo S and the new 911 Turbo S Cabriolet. The firm, sporty padding of the side bolsters and additional shoulder supports provides the best possible hold. And with 18-way electric adjustment, the seats can be optimally adapted to meet your needs in terms of seat height, seat cushion and backrest angle, seat cushion length, fore/aft adjustment, and four-way lumbar support. The steering column is also electrically adjustable.

In addition, the side bolsters on the seat cushion and backrest can be adjusted independently for added comfort on long journeys and precision

lateral support on winding roads.

Also included is the personal memory for all seat positions (apart from the side bolsters) and lumbar support on the driver's side as well as the positions of the steering wheel and exterior mirrors. The memory function also supports settings for the lights, wipers, air conditioning, door locks, PCM, and instrument cluster.

Sport Seats Plus

Available as an option, at no extra cost, are Sport Seats Plus in Leather with power seat height and backrest adjustment as well as mechanical fore/aft adjustment. The side bolsters on the seat cushion and backrest have a firmer, sportier padding and offer excellent lateral support. The backrest

shell is finished in Silver Grey (911 Turbo models) or Leather (911 Turbo S models).

Rear Seats

The rear seats are remarkably comfortable for a sports car. And the shelf behind offers additional storage space. With the backrests folded down, the luggage compartment volume in the 911 Turbo Coupe increases to 9.2 cubic feet, providing plenty of space for luggage. You have 5.5 cubic feet in the new 911 Turbo Cabriolet models.

Child Seats

LATCH child seat preparation including top tether is available for the rear seats as standard.

Seat Heating and Seat Ventilation

Seat heating is available for all seats as an option at no extra charge. Seats are heated in the seat cushion, the backrest, and, for the front seats, the side bolsters. In conjunction with seat heating, we can equip the seats with seat ventilation on request.

A slipstream effect is produced by active ventilation of the perforated seat center and backrest and by passive aeration at the side bolsters. This evaporates perspiration moisture and therefore makes for a dry and pleasant seating environment, even in hot weather.



1



2

1 911 Turbo rear in Yachting Blue | 2 Adaptive Sport Seat Plus



1

HomeLink®

As standard, a HomeLink® system integrated into the overhead console lets you control entry gates, garage doors, lighting systems, and home security systems at the touch of a button. The device allows you to control up to three different systems.

Luggage Compartment

The luggage compartment volume in the new 911 Turbo models is four cubic feet. The luggage compartment is fully trimmed in scratch-resistant materials.

Roof Transport System

An aluminum Roof Transport System is available as an option for the new 911 Turbo Coupe models. It is aerodynamically efficient, very lightweight, and easy to fit. A range of attachments is available, including a roof box, a bike carrier, or a ski/snowboard carrier. The maximum roof load is 165 pounds.

Anti-Theft Protection

The new 911 Turbo models are equipped as standard with an immobilizer with in-key transponder and an alarm system with radar-based interior surveillance.

The system secures the doors, luggage compartment, passenger compartment, and ignition lock.

Auto-Dimming Mirrors

An auto-dimming function is standard for the interior and exterior mirrors. Also included is an integrated rain sensor for the front wiper system.

ParkAssist

ParkAssist at the rear is standard on the new 911 Turbo models. Featuring four inconspicuous sensors in the rear end, the system audibly alerts the driver to the presence of obstacles detected behind the vehicle. An intermittent warning tone increases in rapidity as the obstacle is approached.

In the new 911 Turbo S and the new 911 Turbo S Cabriolet, ParkAssist is supplemented by four sensors

at the front (available as an option for the new 911 Turbo and the new 911 Turbo Cabriolet). The audible alert is supplemented by a visual warning in the central display screen, which shows a graphical representation of the vehicle from overhead.



2



3

1 Roof Transport System | 2 Luggage compartment | 3 Graphical display of ParkAssist (front and rear)

Light Design Package

The optional light design package is both practical and aesthetically appealing. It comprises dimmable LEDs in the overhead console and in the areas of the rear seats, door openers, door storage compartments, and front footwells.

Porsche Entry & Drive

With the optional Porsche Entry & Drive, you can leave your car key in your pocket. As soon as you grab the door handle or approach the luggage compartment, the system automatically checks the encrypted access code on the key. Once the key is validated, the door and the luggage compartment lid unlock. The engine can then be started and switched off using the electronic ignition switch.

To lock the vehicle, you simply press the button on the outside of the door handle. Porsche Entry & Drive then locks the vehicle and activates the engine immobilizer and steering-column lock.

Glass Tilt/Slide Sunroof

For the 911 Turbo Coupe models, a power-adjustable tilt/slide sunroof is available in tinted single-glazed safety glass.

An integral power sunblind provides shade from unwanted bright light. The design, headroom, and aperture of the glass roof are identical to those of the steel tilt/slide sunroof. The only difference is that, even when closed, the glass sunroof still gives you that open-to-the-sky feeling.

Reversing Camera

The optional reversing camera (only in conjunction with ParkAssist front and rear) facilitates reverse parking and maneuvering. Help is provided in the form of a high-contrast color image with dynamic guidelines on the PCM screen, which shows the predicted course of the vehicle based on the current position of the steering wheel.

Cruise Control

For greater driver comfort on long stretches of road, this automatic speed control function is standard on the 911 Turbo and Turbo S models. Cruise control operates above 19 mph and is activated using a button on the steering-column control stalk.

Adaptive Cruise Control Including Porsche Active Safe (PAS)

Available as an option, this cruise control function regulates your speed according to the distance between your vehicle and the vehicle in front. A radar sensor monitors the road ahead at up to a distance of 656 feet. If you have set a cruising speed but have begun to gain on the vehicle in front because it is driving more slowly, this is detected by the radar sensor.

The system now reduces the speed of your vehicle up to a maximum rate of 11 ft./sec by restricting the throttle or gently applying the brakes, until the distance that you have preset is maintained. Your vehicle will now continue at a reduced

speed. If the other vehicle decelerates further, Adaptive Cruise Control will continue to reduce your cruising speed—even down to a complete stop.

For additional safety, if the system detects that the distance from the vehicle in front is decreasing, it will also prepare your vehicle for braking by precharging the braking system so that the brake pads are already in light contact with the brake discs. However, drivers still have to perform heavier braking themselves.

As soon as the road ahead clears again, your vehicle will accelerate back up to the cruising speed originally set.



1 Adaptive Cruise Control radar sensor | 2 Adaptive Cruise Control display



Powerful, functional, and easy to use.

Isn't that how everything in a Porsche is supposed to be?

Audio and communication.

Porsche Communication Management (PCM)

Including Navigation Module

Porsche Communication Management (PCM) is standard equipment in the new 911 Turbo models. PCM is your control center for audio, navigation, and communication functions.

The main feature is the intuitive 7-inch color touchscreen. Or you can choose to operate PCM using conventional rotary push-button controls. With a maximum of five list items per page,

the screen display is very clearly presented. Radio functions include up to 42 memory presets and an FM twin-tuner frequency diversity with RDS, which continuously scans in the background for the best signal.

The DVD audio drive plays CDs and audio DVDs and is MP3-compatible. Audio playback of video DVDs is also supported. A 6-disc CD/DVD changer integrated into PCM is available as an option.

The standard universal audio interface (AUX) USB port in the glove compartment enables you to connect your iPod® or any audio source. Recharging is also supported. Once connected, your iPod® or USB stick is then conveniently and safely operated via the PCM, the optional multifunction steering wheel, or the optional voice-control system.

Podcasts and audiobooks are recognized and played and cover art is displayed. The navigation module in PCM allows you

to choose between a 2-D display and a 3-D perspective. In some regions, it is possible to display the terrain (with a superimposed satellite map) and buildings in 3-D. Split-screen mode enables you to view two functions at once, such as the current navigation map and a list of symbols that represent the next driving maneuver.

Electronic Logbook

An electronic logbook is available for PCM as an option. It lets you automatically keep logs on every journey of mileage, route distance, date, time, starting location, and destination. Data can be downloaded to a USB stick and evaluated on your home PC using the software supplied.

Bluetooth® Hands-Free Profile (HFP)

A standard Bluetooth® interface lets you connect your Bluetooth®-enabled mobile phone to the PCM with Hands-Free Profile (HFP), allowing you to receive and place calls. Basic functions can be controlled via PCM or the optional multifunction steering wheel.

Telephone Module

The optional quad-band GSM telephone module offers convenience and excellent reception. The Bluetooth® capability of

a mobile phone can be used to make calls via the SIM Access Profile (SAP). Once automatic pairing is complete, the mobile phone's antenna is switched off to conserve battery charge and the phone operates via the car antenna. Depending on the mobile phone model, this gives access not only to the numbers on the SIM card, but also to the phone's internal memory. Depending on the phone, it can also be controlled using PCM, the optional multifunction steering wheel, or the optional voice-control system, without it ever leaving your pocket.

The telephone module also enables you to establish a Bluetooth® link with those mobile phones that support only the Hands-Free Profile (HFP). In this case, the GSM connection is always established through the antenna of the mobile phone. PCM acts as a hands-free system and you can leave the mobile phone tucked away.

On request, a cordless handset for the telephone module is also available. Stored in the center console storage compartment, it features a display and keypad. However, the handset cannot be used for Bluetooth® links established using the Hands-Free Profile (HFP).

Voice-Control System

Want route guidance, need to make a phone call, or like to listen to the radio? You just have to say so. Almost all of the functions of PCM can be controlled using the optional voice-control system with word-by-word input. In the majority of cases, you can simply say the name of the menu item as seen on the screen. The voice-control system understands complete addresses when entered as navigation destinations, as well as phonebook entries and the names of radio stations. Even lists can be browsed by voice command. There is no need to train the system.

SiriusXM® Satellite Radio Receiver

The SiriusXM® Satellite Radio receiver is standard on all 911 Turbo models and includes a three-month free trial period.* This service provides over 130 channels coast to coast, including commercial-free music, plus the best sports, news, talk, comedy, and entertainment. Welcome to the world of satellite radio.

Sports and stocks, also provided by SiriusXM®, give you customized updates on your favorite teams and stocks, so you can arrive at your destination well-informed.

The optional NavTraffic® service, available with SiriusXM®, enables PCM to display continuously updated traffic information in over 130 markets. Avoid congestion before you reach it with information on traffic speed, accidents, construction, and road closings.

The optional SiriusXM® NavWeather® service, available with SiriusXM®, allows you to stay informed with driver-friendly weather information on the PCM screen. See storms and severe weather, keep track of weather warnings, and see the current conditions and 3-day forecasts.

HD Radio Receiver

For the first time, an HD Radio receiver is now available as standard on the 911 Turbo models. HD Radio technology provides access to all of your favorite FM

stations plus a broad range of new digital programming. HD Radio also includes advanced audio and data features that enhance your listening experience.

Online Services

The free Aha® Radio app enables you to listen to Internet radio, news feeds, podcasts, and audiobooks on the PCM via your smartphone when combined with the optional online services. You can also receive local information, e.g., weather reports. Points of Interest can

be searched for and then transferred to the navigation system as destinations. Internet content is received via your smartphone but you operate everything from the PCM. Online Services can only be used in conjunction with the standard universal audio interface (iPhone®) or the

optional mobile phone preparation or telephone module (Android™ phones).

The Aha® Radio app can be obtained from iTunes® and Google Play™.**

*SiriusXM® Radio requires a subscription, sold separately after any trial included with vehicle purchase or lease. **If you decide to continue your SiriusXM® service at the end of your subscription, service will automatically renew and bill until you call SiriusXM® at 1-866-635-2349 to cancel.** See SiriusXM® Customer Agreement for complete terms at www.siriusxm.com. Satellite service available only to those at least 18 and older in the 48 contiguous United States and D.C. Sirius, XM, and all related marks and logos are trademarks of SiriusXM® Radio Inc.

**In order to use Aha® Radio services with the optional telephone module, the HFP function must be activated in PCM.
1 Electronic logbook





Bose® Surround Sound System

The sound of a Porsche is as unique as a fingerprint. And that's true not just of the engine's sound. The Bose® Surround Sound System, which comes standard, is perfectly tuned to the specific interior acoustics of the 911 Turbo models.

The system has eight amplifier channels, 12 loudspeakers, and a patented integral 100-watt active subwoofer and a total output of 445 watts. The combined effect is a balanced acoustic pattern that transforms your 911 Turbo into a concert hall. An extremely fast-moving one.

The Bose® Surround Sound System enables audio playback of DVDs and makes full use of the impressive sound spectrum of 5.1 digital recordings. Of

course, you can still play other audio sources, such as CDs and MP3s—in stereo. Or, at the push of a button, in one of the virtual surround modes generated by Bose® Centerpoint®2.

The Bose®-patented AudioPilot® Noise Compensation Technology uses a microphone to continuously measure the ambient noise inside the vehicle. It then instantly adapts music playback automatically so that a consistent sound is maintained, whatever the driving conditions.

The result is a powerful sound and captivating 360-degree acoustic experience.

Burmester® High-End Surround Sound System

When two iconic German manufacturers join forces, the result is special. We're referring to Porsche and Berlin-based Burmester®, one of the most respected manufacturers of high-end audio equipment worldwide. The Burmester® High-End Surround Sound System is based on the finest premium home audio systems Burmester® has to offer. The technologies behind the system optimize countless details of audio design, with one goal: sound perfection.

The system boasts 12 amplifier channels with a total output of more than 821 watts, 12 loudspeakers including an active subwoofer with 300-watt Class D amplifier, a total diaphragm surface area of more than 207 square inches, and a frequency response of 35 Hz to 20 kHz.

The Burmester® system uses the patented integral subwoofer, which replaces the familiar separate subwoofer and loudspeaker arrangement of other systems. This saves weight and has a beneficial impact on acoustic performance.

Crossover technology has been carried over more or less unmodified from the home audio sector. Analog and digital filters have been optimally defined for their new installation location and finely tuned after extensive in-car audio testing.

For unmistakably fine, clear, and undistorted high-frequency sound reproduction with excellent level stability, ribbon-based Air Motion Transformers (AMT) have been used for all of the 911 Turbo models. All loudspeaker housings

are perfectly matched and deliver superior bass foundation, definition, and impulse accuracy. The result is a natural and richly textured spatial sound even at top volume.

The pure, sporty design with galvanized surrounds and Burmester® logos on select loudspeakers makes it clear that the appeal of the Burmester® High-End Surround Sound System is as much about the visual as it is the audio. Uncompromising in sound and design. Typically Porsche.

There is an exception to every rule.

Personalization.

The central idea of the 911 Turbo is clearly defined. It just needs your interpretation of what makes a sports car so fascinating.

A variety of personalization options is available for both the exterior and the interior.

These are not the only ways to style your 911 Turbo to your personal preference. How about the personalization of your car at the factory through Porsche Exclusive? Or why not consider our range of aftermarket accessories from Porsche Tequipment?

As you are inspired by ideas, your Authorized Porsche dealer will be happy to advise you.



Standard colors.

Solid exterior colors.

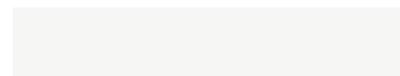

White



Racing Yellow



Guards Red

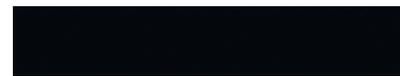

Black



Standard colors.

Metallic exterior colors.



Rhodium Silver Metallic



Sapphire Blue Metallic



Amaranth Red Metallic



Mahogany Metallic



Dark Blue Metallic



Anthracite Brown Metallic



Agate Grey Metallic



Basalt Black Metallic

Special exterior colors.



GT Silver Metallic



Lime Gold Metallic



Cabriolet top colors.



Red



Brown



Blue



Black

Standard interior colors.

Leather.



Black

Luxor Beige

Platinum Grey

Carpet.



Black

Luxor Beige

Platinum Grey

Floor mats.



Black

Luxor Beige

Platinum Grey

Roof liner.



Black

Luxor Beige

Platinum Grey

Standard interior colors.

Leather.



Yachting Blue

Black and Carrera Red¹

Agate Grey

Carpet.



Yachting Blue

Carrera Red

Agate Grey

Floor mats.



Yachting Blue

Carrera Red

Agate Grey

Roof liner.



Black

Black

Agate Grey

¹For 911 Turbo S only.

Two-tone combination interior.

Leather.



Black and Platinum Grey

Agate Grey and Pebble Grey

Black and Luxor Beige

Carpet.



Platinum Grey

Pebble Grey

Luxor Beige

Floor mats.



Platinum Grey

Pebble Grey

Luxor Beige

Roof liner.



Platinum Grey

Agate Grey

Black

Natural Leather interior.

Leather.



Espresso

Carrera Red

Espresso and Cognac

Carpet.



Espresso

Carrera Red

Cognac

Floor mats.



Espresso

Carrera Red

Cognac

Roof liner.



Espresso

Black

Espresso



Rear wiper



Electric tilt/slide sunroof

Product	911 Turbo	911 Turbo S	911 Turbo Cabriolet	911 Turbo S Cabriolet	Code	Page
Exterior.						
Special colors	<input type="checkbox"/>	<input type="checkbox"/>	<input type="checkbox"/>	<input type="checkbox"/>	Code	92
Colors to sample	<input type="checkbox"/>	<input type="checkbox"/>	<input type="checkbox"/>	<input type="checkbox"/>	Code	
Trim strips in a high-gloss finish	<input type="checkbox"/>	<input type="checkbox"/>	<input type="checkbox"/>	<input type="checkbox"/>	559	
LED headlights including Porsche Dynamic Light System Plus (PDLS Plus)	<input type="checkbox"/>	<input checked="" type="checkbox"/>	<input type="checkbox"/>	<input checked="" type="checkbox"/>	602	58
Porsche Entry & Drive	<input type="checkbox"/>	<input type="checkbox"/>	<input type="checkbox"/>	<input type="checkbox"/>	625	81
Deletion of model designation	<input type="checkbox"/>	<input type="checkbox"/>	<input type="checkbox"/>	<input type="checkbox"/>	498	
911 logo	<input type="checkbox"/>	<input type="checkbox"/>	<input type="checkbox"/>	<input type="checkbox"/>	911	
ParkAssist (front and rear)	<input type="checkbox"/>	<input checked="" type="checkbox"/>	<input type="checkbox"/>	<input checked="" type="checkbox"/>	636	80
ParkAssist (front and rear including reversing camera) ¹	<input type="checkbox"/>	<input type="checkbox"/>	<input type="checkbox"/>	<input type="checkbox"/>	638	81
Rear wiper	<input type="checkbox"/>	<input type="checkbox"/>	<input type="checkbox"/>	<input type="checkbox"/>	425	
Electrically folding exterior mirrors	<input type="checkbox"/>	<input type="checkbox"/>	<input type="checkbox"/>	<input type="checkbox"/>	748	
SportDesign exterior mirrors	<input type="checkbox"/>	<input checked="" type="checkbox"/>	<input type="checkbox"/>	<input checked="" type="checkbox"/>	529	
Electric tilt/slide sunroof	<input checked="" type="checkbox"/>	<input checked="" type="checkbox"/>	<input type="checkbox"/>	<input type="checkbox"/>	651	81
Electric glass tilt/slide sunroof	<input type="checkbox"/>	<input type="checkbox"/>	<input type="checkbox"/>	<input type="checkbox"/>	653	81
Roof Transport System	<input type="checkbox"/>	<input type="checkbox"/>	<input type="checkbox"/>	<input type="checkbox"/>	549	80

– not available extra-cost option standard equipment available at no extra cost

Product	911 Turbo	911 Turbo S	911 Turbo Cabriolet	911 Turbo S Cabriolet	Code	Page
Engine and chassis.						
Porsche Ceramic Composite Brakes (PCCB)	<input type="checkbox"/>	<input checked="" type="checkbox"/>	<input type="checkbox"/>	<input checked="" type="checkbox"/>	450	64
Porsche Dynamic Chassis Control (PDCC)	<input type="checkbox"/>	<input checked="" type="checkbox"/>	<input type="checkbox"/>	<input checked="" type="checkbox"/>	352	53
Sport Chrono Package	<input type="checkbox"/>	<input checked="" type="checkbox"/>	<input type="checkbox"/>	<input checked="" type="checkbox"/>	640	43
Power Steering Plus	<input type="checkbox"/>	<input type="checkbox"/>	<input type="checkbox"/>	<input type="checkbox"/>	658	
Sport tailpipes ²	<input type="checkbox"/>	<input type="checkbox"/>	<input type="checkbox"/>	<input type="checkbox"/>	138	
Wheels.						
20-inch 911 Turbo wheels	<input checked="" type="checkbox"/>	<input type="checkbox"/>	<input checked="" type="checkbox"/>	<input type="checkbox"/>	429	52
20-inch 911 Turbo S wheels	<input type="checkbox"/>	<input checked="" type="checkbox"/>	<input type="checkbox"/>	<input checked="" type="checkbox"/>	435	52
Wheel centers	<input type="checkbox"/>	<input type="checkbox"/>	<input type="checkbox"/>	<input type="checkbox"/>	446	

¹Available from 11/2013 at the earliest.

²Available from 03/2014 at the earliest.



Sport tailpipes



20-inch 911 Turbo S wheel



20-inch 911 Turbo wheel



Multifunction steering wheel



Adaptive Cruise Control including Porsche Active Safe (PAS)

Product	911 Turbo	911 Turbo S	911 Turbo Cabriolet	911 Turbo S Cabriolet	Code	Page
Interior.						
Adaptive Cruise Control including Porsche Active Safe (PAS)	<input type="radio"/>	<input type="radio"/>	<input type="radio"/>	<input type="radio"/>	456	81
Multifunction steering wheel	<input type="checkbox"/>	<input type="checkbox"/>	<input type="checkbox"/>	<input type="checkbox"/>	844	
Light design package	<input type="radio"/>	<input type="radio"/>	<input type="radio"/>	<input type="radio"/>	630	81
Sport Seats Plus (4-way, electric)	<input type="checkbox"/>	<input type="checkbox"/>	<input type="checkbox"/>	<input type="checkbox"/>	P05	77
Power Sport Seats (14-way, electric)	<input checked="" type="checkbox"/>	<input type="checkbox"/>	<input checked="" type="checkbox"/>	<input type="checkbox"/>	P06	77
Adaptive Sport Seats Plus (18-way, electric)	<input type="radio"/>	<input checked="" type="radio"/>	<input type="radio"/>	<input checked="" type="radio"/>	P07	77
Seat heating	<input type="checkbox"/>	<input type="checkbox"/>	<input type="checkbox"/>	<input type="checkbox"/>	342	78
Seat ventilation	<input type="radio"/>	<input type="radio"/>	<input type="radio"/>	<input type="radio"/>	541	78
Steering wheel heating	<input type="radio"/>	<input type="radio"/>	<input type="radio"/>	<input type="radio"/>	345	

Product	911 Turbo	911 Turbo S	911 Turbo Cabriolet	911 Turbo S Cabriolet	Code	Page
Interior.						
Fire extinguisher	<input type="radio"/>	<input type="radio"/>	<input type="radio"/>	<input type="radio"/>	509	
Smoking package	<input type="checkbox"/>	<input type="checkbox"/>	<input type="checkbox"/>	<input type="checkbox"/>	583	
Luggage net in passenger footwell	<input type="checkbox"/>	<input type="checkbox"/>	<input type="checkbox"/>	<input type="checkbox"/>	581	
Interior: Leather and Natural Leather.						
Leather interior						
– in 911 Turbo standard color	<input checked="" type="checkbox"/>	<input type="checkbox"/>	<input checked="" type="checkbox"/>	<input type="checkbox"/>	Code	93, 94
– in 911 Turbo S standard color	–	<input checked="" type="checkbox"/>	–	<input checked="" type="checkbox"/>	Code	93, 94
– in special color	<input type="radio"/>	<input type="checkbox"/>	<input type="radio"/>	<input type="checkbox"/>	Code	94
– in two-tone combination	<input type="radio"/>	<input type="checkbox"/>	<input type="radio"/>	<input type="checkbox"/>	Code	95
– in Natural Leather	<input type="radio"/>	<input type="radio"/>	<input type="radio"/>	<input type="radio"/>	Code	96
– in Natural Leather two-tone combination	<input type="radio"/>	<input type="radio"/>	<input type="radio"/>	<input type="radio"/>	Code	96
– in color to sample	<input type="radio"/>	<input type="radio"/>	<input type="radio"/>	<input type="radio"/>	Code	

– not available extra-cost option standard equipment available at no extra cost



Leather interior package in Luxor Beige



Natural Leather interior package in Espresso



6-disc CD/DVD changer



Cordless handset for telephone module

Product	911 Turbo	911 Turbo S	911 Turbo Cabriolet	911 Turbo S Cabriolet	Code	Page
Audio and communication.						
Burmester® High-End Surround Sound System	○	○	○	○	682	88
Electronic logbook	○	○	○	○	641	85
Voice-control system	○	○	○	○	671	85
Telephone module	○	○	○	○	666	85
Cordless handset for telephone module	○	○	○	○	669	85
6-disc CD/DVD changer ¹	○	○	○	○	693	84
Online Services ²	○	○	○	○	UN1	86

¹May be incompatible with some copy-protected CDs.

²To use Online Services with the optional telephone module, the HFP function must be activated in PCM.

– not available ○ extra-cost option ● standard equipment □ available at no extra cost



Porsche Exclusive.

A distinctive identity is another form of exclusivity.

Everything starts with the right advice to complement your exclusive wishes and requirements. We offer personal support and individual expert advice to each and every customer. So why wait? Make an appointment with your Authorized Porsche dealer to discuss your requirements.

For the truly personal touch, contact our Porsche Customer Consultation Specialists at customerconsultations@porsche.us.

By making an appointment to visit our Customer Consultation Center in Beverly Hills, California, you can select

the materials, such as Leather, Wood, Carbon, or Aluminum, and the paint finish you desire. With the advanced Porsche Car Configurator, you will be able to see a nearly life-size wall display of your creation. We want to show you what we can do and experience how we turn customer requirements into reality.

The Porsche New-Vehicle Limited Warranty applies for all Porsche Exclusive options and special designs. Please understand that some Porsche Exclusive options may require a longer delivery lead time.

A Special Exclusive Interior

An exquisite interior—a two-tone Leather in Agate Grey and Lime Gold. Another highlight is decorative stitching in Lime Gold, as featured on the personalized floor mats with Leather edging.

Further refinements to do credit to the 911 Turbo in Lime Gold Metallic as a Porsche Exclusive car? The Carbon interior package, central console trim strips in Carbon, as well as the personalized illuminated door-entry guards in Carbon.

In addition to high-tech Carbon, hard-wearing Alcantara® has also been incorporated: on the SportDesign steering wheel and on the PDK selector.



1 Carbon interior package, central console trim in Carbon, SportDesign steering wheel in Alcantara®, PDK selector in Alcantara®, individual floor mats with Leather trim



2 Sport Seat Plus Leather backrest



Personalized Illuminated Door-Entry Guards in Carbon

These door-entry guards—with white, custom illuminated lettering—highlight sports performance and extravagance in equal measure.

20-Inch Sport Classic Wheels Painted in Black (High-Gloss)

Five-spoke, 20-inch forged aluminum wheels with polished rims. Another highlight: The wheel bears a striking resemblance to the world-renowned Fuchs® wheels.



Sport Seats Plus Leather Backrests

The backrests are covered with a classic natural material: timeless, hard-wearing Leather.

2 Sport Seat Plus Leather backrest

3 Individual door-entry guards in Carbon, illuminated

4 20-inch Sport Classic wheel painted in black (high-gloss)

Porsche Car Configurator.

Create your own identity.

Taste, personality, style. You decide how to refine the 911 Carrera to your personal preference. With the Porsche Car Configurator, you can see the result instantly on your computer. Just four simple steps is all it takes to create the Porsche of your dreams. The Configurator allows you to select and deselect your options with ease, the price being calculated instantly every time. All equipment and selections can be displayed in 3-D to provide you with an excellent overview of your chosen car. You can also view your configuration from all angles, save it, and print it out directly.

To access the Porsche Car Configurator and find out more about the captivating power of Porsche, please visit porscheusa.com.

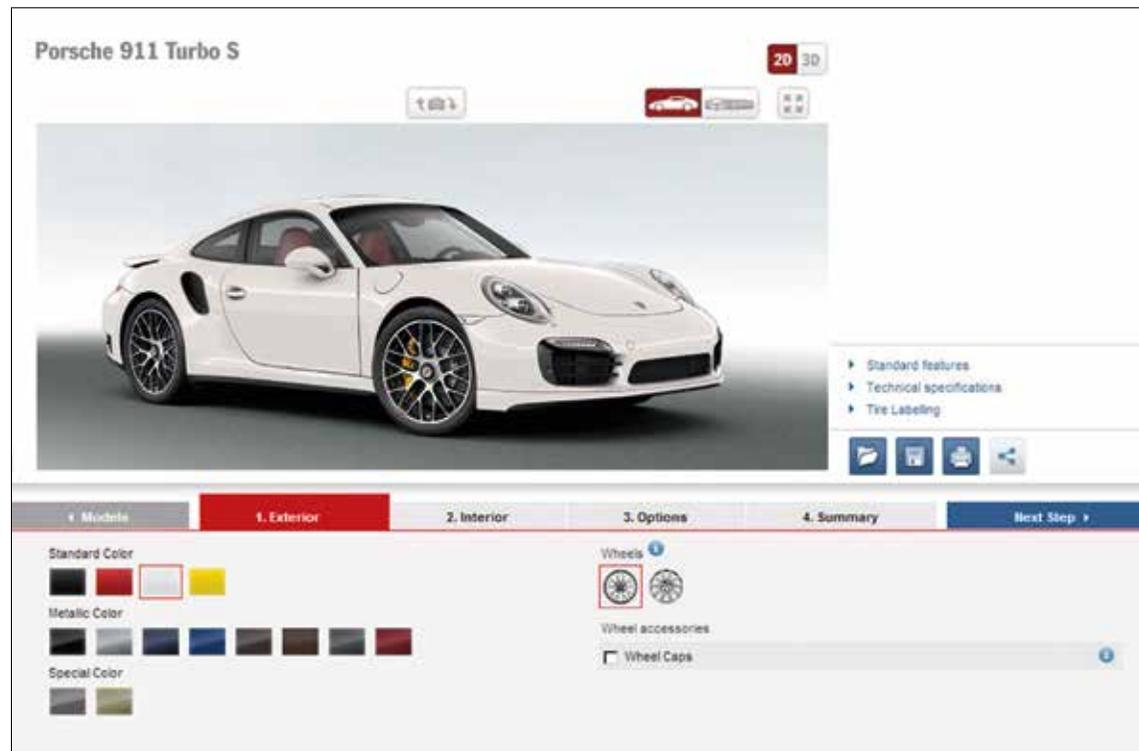

European Delivery

The first time that you drive your new Porsche will be a truly special moment. Nevertheless, you can make it even more special with Porsche European Delivery. Come and collect your Porsche in Stuttgart-Zuffenhausen or Leipzig and be the one to take it to its rightful place: on the road.

Before this, we invite you behind the scenes of the Porsche production process. As part of a guided factory tour, you will see how much passion

and precision goes into everything we do. You can then take time to reflect on your experience over a leisurely lunch and look forward to the high point of the day: taking delivery of your Porsche. Our specialists will take their time to explain everything about your new car in as much detail as you wish.

That leaves you with just one more thing to decide: from which factory to collect your Porsche? Stuttgart-Zuffenhausen is steeped in tradition and history. Here,

you can visit the Porsche Museum to experience and learn about every aspect of the Porsche marque, with legendary models from a sports car history spanning over 60 years.

Or, if you would prefer your factory collection to be a little more on the sporty side, visit our production location in Leipzig. Your first driving experience will be a test drive in a Porsche model identical to the one you purchased and under the expert supervision of one of

our instructors. Hone your skills on-road on the FIA-certified test circuit or off-road in a Porsche off-roader on our very own off-road track.

For more information, please contact your Authorized Porsche dealer to arrange a collection date. Your dealer will be happy to assist in the planning of your trip.



Porsche Driving Experience.

Porsche Travel Club

With the Porsche Travel Club, your holiday begins the moment you step inside the vehicle. Leave everyday life behind and join us in one of the most beautiful regions in the world. We look

forward to having you as our guest.

Whether you are here for several hours or several days, your constant companion will be a Porsche. A unique experience awaits and includes an exclusive hospitality package. You will stay in first-

class hotels and dine in the finest restaurants your chosen route has to offer. The Porsche Travel Club gives you access to the very thing that words cannot describe: the authentic driving feel of a Porsche.

Please visit porscheusa.com/travelclub to find out more.

Porsche Sport Driving School

Located in Birmingham, Alabama, this is where you can learn driving technique from professional instructors on a world-class road racing circuit.

Under the guidance of our Porsche Certified Instructors, you will learn not only the basics, but the fine points of the sport as well. Perfecting the most efficient driving line, the importance of being smooth, trail braking techniques, heel/toe downshifting,

and refining your car control skills are all part of the curriculum.

All of our courses are designed to finely hone your driving style step by step, with professional instructors at your side, on- and off-road.

For Porsche Sport Driving School course descriptions and dates, visit our website at porschedriving.com.



Panorama.



Porsche European Delivery

Imagine touring the original factory and then being handed the keys for an even more gratifying opportunity: touring Europe in your brand-new Porsche vehicle. What happens next is up to you. Contact your local Authorized Porsche dealer for more information.



Porsche Exclusive

Realize your vision of the perfect Porsche with our factory customization program. From styling enhancements to performance upgrades, all modifications are uniquely handcrafted for your Porsche.



Porsche Tequipment

Personalize your Porsche at any time after purchase with the Tequipment range of approved accessories. Designed exclusively for your Porsche, every product is fully guaranteed.



Porsche Roadside Assistance

Your ownership experience is enhanced with complimentary enrollment in the Porsche 24-Hour Roadside Assistance program. It includes coverage 24 hours a day, 365 days a year, for the duration of your warranty. Contact your Authorized Porsche dealer for specifics.



Porsche Financial Services

Competitive, convenient, and carefully crafted financing options can be customized to meet your needs. Ask your certified Porsche Sales Consultant for details.



Porsche Driver's Selection

Our distinctive collection of clothing and accessories combines timeless elegance with unmistakable quality. Visit your Authorized Porsche dealer or shop online at porscheusa.com/shop.



Porsche Online

Explore the world of Porsche at porscheusa.com. News, information, and videos are at your fingertips. Even create a car as individual as you are with the online Porsche Car Configurator.

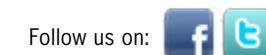

Follow us on:

Porsche Approved Certified Pre-Owned

A meticulous 111-point inspection, a 2-year or 50,000-mile limited warranty, and 24-Hour Roadside Assistance make this program one of a kind. Contact your Authorized Porsche dealer for details.



Porsche Classic

Your specialist source for genuine Porsche parts and technical documentation, as well as servicing, repair, and restoration for all types of Porsche classics. For more information, visit porscheusa.com/classic.



Christophorus

Our bimonthly magazine for Porsche owners is packed with news, articles, and exclusive interviews covering every aspect of Porsche automobiles and the Porsche lifestyle.



Porsche Travel Club

Exclusive driving holidays and incentive ideas combining luxury and adventure, worldwide. To find out more, contact us by e-mail at travel.club@porsche.us.



Porsche Sport Driving School

Develop your skill and explore your Porsche with the Porsche Sport Driving School. Learn firsthand from famed Porsche Racing drivers while they teach you at a world-class racing facility. Visit porschedriving.com for more information.



Porsche Clubs

With more than 120,000 members worldwide in 60 countries, know you are not alone in your passion for Porsche. Learn more about the brand and meet other Porsche enthusiasts just like yourself. Visit porscheusa.com for more information.



Porsche Museum

More than 80 vehicles are waiting to take you back through every stage of Porsche history. They include such icons as the 356, 911, and 917, and many other special exhibits presented in an atmosphere you can't experience anywhere else.



You can obtain the latest brochures for Porsche Exclusive, Porsche Tequipment, Porsche Driver's Selection, and Porsche Sport Driving School from your Authorized Porsche dealer.

The sum of our experience.

Since the first 911 Turbo in 1974, Porsche has dedicated four decades of research and development to the concept of the turbocharged sports car. With each new generation, the 911 Turbo has moved the benchmarks for intelligent sports car performance. Boosting power while minimizing fuel consumption. Sharpening the response of the chassis through electronic controls—without dulling the senses of the driver. Refining comfort and convenience without sacrificing sportiness.

That is the sum of our experience. It's time to make a 911 Turbo part of your experience. The only remaining question is, which one?

The new 911 Turbo models.



Technical data.

	911 Turbo Coupe/911 Turbo Cabriolet	911 Turbo S Coupe/911 Turbo S Cabriolet
Engine		
Cylinders	6	6
Displacement	3.8 liters	3.8 liters
Power at rpm	520 hp @ 6000–6500 rpm	560 hp @ 6500–6750 rpm
Max. torque at rpm	487 lb.-ft. @ 1950–5000 rpm	516 lb.-ft. @ 2100–4250 rpm
Max. torque with overboost at rpm	524 lb.-ft. @ 2100–4250 rpm	553 lb.-ft. @ 2200–4000 rpm
Compression ratio	9.8:1	9.8:1
Transmission		
Layout	Active all-wheel drive	Active all-wheel drive
PDK	7-speed	7-speed
Chassis		
Front axle	MacPherson strut suspension with anti-roll bar	MacPherson strut suspension with anti-roll bar
Rear axle	Multi-link suspension	Multi-link suspension
Steering	Electromechanical power steering with electrical power	Electromechanical power steering with electrical power
Turning circle	34.8 ft.	34.8 ft.
Brakes	6-piston, aluminum monobloc fixed calipers at front, 4-piston, aluminum monobloc fixed calipers at rear, discs internally vented and cross-drilled, closed calipers, brake calipers in red	6-piston, aluminum monobloc fixed calipers at front, 4-piston, aluminum monobloc fixed calipers at rear, carbon ceramic composite brake discs, vented and cross-drilled, closed calipers, brake calipers in yellow
Vehicle stability system	Porsche Stability Management (PSM)	Porsche Stability Management (PSM)
Standard wheels	Front: 8.5J x 20 RO 51; Rear: 11J x 20 RO 56	Front: 9J x 20 RO 51; Rear: 11.5J x 20 RO 56
Standard tires	Front: 245/35 ZR 20; Rear: 305/30 ZR 20	Front: 245/35 ZR 20; Rear: 305/30 ZR 20

	911 Turbo Coupe	911 Turbo Cabriolet	911 Turbo S Coupe	911 Turbo S Cabriolet
Weights				
Curb weight	3,516 lb.	3,671 lb.	3,538 lb.	3,693 lb.
GVWR	4,387 lb.	4,508 lb.	4,387 lb.	4,508 lb.
Performance				
Top track speed	195 mph	195 mph	197 mph	197 mph
0–60 mph	3.2 secs	3.3 secs	–	–
0–60 mph with Sport Plus button	3.0 secs	3.1 secs	2.9 secs	3.0 secs
1/4 mile	11.3 secs	11.5 secs	–	–
1/4 mile with Sport Plus button	11.1 secs	11.3 secs	10.9 secs	11.1 secs
Fuel consumption/emissions*				
City	17 mpg	17 mpg	17 mpg	17 mpg
Highway	24 mpg	24 mpg	24 mpg	24 mpg
Combined	20 mpg	20 mpg	20 mpg	20 mpg
Dimensions/aerodynamics				
Length	177.4 in.	177.4 in.	177.4 in.	177.4 in.
Width	74.0 in.	74.0 in.	74.0 in.	74.0 in.
Height	51.0 in.	50.9 in.	51.0 in.	50.9 in.
Wheelbase	96.5 in.	96.5 in.	96.5 in.	96.5 in.
Luggage compartment volume	9.18 cu. ft.	9.18 cu. ft.	9.18 cu. ft.	9.18 cu. ft.
Trunk capacity	4.06 cu. ft.	4.06 cu. ft.	4.06 cu. ft.	4.06 cu. ft.
Tank capacity (refill volume)	17.9 gal.	17.9 gal.	17.9 gal.	17.9 gal.
Drag coefficient	0.31	0.31	0.31	0.31

*2013 U.S. EPA estimates. Your mileage may vary

Index.

A	Colors	F	M	Porsche Communication Management (PCM) including navigation module	S	V
Adaptive Cruise Control including Porsche	Exterior	Fuel	Materials	(PCM) including navigation module	Safety	Variable Turbine Geometry (VTG)
Active Safe (PAS)	Interior	Fuel consumption	Mobile phone preparation	Porsche Doppelkupplung (PDK)	Seat heating	VarioCam Plus system
Airbags	Comfort	Fuel system		Porsche Dynamic Chassis Control (PDCC)	Seats	Voice-control system
Anti-theft protection	Communication		N	Porsche Dynamic Light System (PDLS)	Seat ventilation	
Auto Start Stop function	Cruise control		Noise	Porsche Dynamic Light System Plus (PDLS Plus)	Sport button	W
		H		Porsche Entry & Drive	Sport Chrono Package	Wheels
B	D	Headlight-cleaning system	O	Porsche Side Impact Protection (POSIP) system	Sport Plus button	Wind deflector, electric
Bi-Xenon™ headlights including Porsche	Design	HomeLink® (programmable garage door opener)	Onboard computer	Porsche Stability Management (PSM)	Steering wheels	
Dynamic Light System (PDLS)	Digital radio		Online Services	Porsche Torque Vectoring Plus (PTV Plus)	Stereo lambda sensors	
Bodyshell	Direct Fuel Injection (DFI)	I		Porsche Traction Management (PTM)		
Bose® Surround Sound System	Dry-sump lubrication, integrated	Instruments	P		T	
Brakes		Interior	Panorama	Rear differential lock	Technical data	
Burmester® High-End Surround Sound System	E		ParkAssist	Rear-axle steering	TFT display	
	Electrical system recuperation	L	Parking brake, electric	Rearview mirror, auto-dimming	Thermal management	
	Emissions control	Leather	Performance display	Recycling	Tilt/slide glass sunroof	
C	Engine	LED headlights including Porsche Dynamic Light System Plus (PDLS Plus)	Personalization	Reversing camera	Tire Pressure Monitoring System (TPMS)	
Catalytic converter	Engineering	Lighting	Porsche Active Aerodynamics (PAA)	Rollover protection	Transmission	
CD/DVD changer	Engine management, electronic	Logbook, electronic	Porsche Active Suspension Management (PASM)	Roof Transport System		
Chassis	Engine mounts, dynamic	Luggage compartment	Porsche Ceramic Composite Brakes (PCCB)			
Coasting	Environment					
	Expansion intake manifold					
	Exterior mirrors, auto-dimming					