

2010 Tribeca



Love. It's what makes a Subaru, a Subaru.





Love the possibilities.

A new hobby. A new tradition. A new member of the family. A new adventure every day. Subaru vehicles are uniquely designed and equipped to get you out, to keep you going, and to inspire you to embrace more of life's opportunities. It all starts with the balance of Subaru Symmetrical All-Wheel Drive. Standard on every Subaru, it gives you the stability and control to drive where you want, when you want—always with the greatest confidence. That poise is matched with the reassurance of being protected by award-winning safety. It's why we hear again and again, "I love my Subaru."

Love. It's what makes a Subaru, a Subaru.



Introducing the 2010 **Subaru Tribeca**.

When you set out to see more of the world,
choose a vehicle that fits more of your life.





All wheels. All roads.

All the time.

By combining the balance and road adhesion of Subaru Symmetrical All-Wheel Drive with the stability of the SUBARU BOXER® engine, Subaru builds more than cars—we build confidence. Confidence that can help you enjoy getting there as much as being there. And can help you feel the freedom to live more of the life you love.

Better grip for more confidence.

Subaru Symmetrical All-Wheel Drive

Whether it's over scenic byways and up to the mountains, or down the street to the grocery store, control of your vehicle comes from one place—where your tires meet the road. A sure grip of the road can give you the control to step around danger, and the engagement to find exhilaration in every strip of asphalt. Subaru has spent nearly 40 years developing a system for traction and control that employs an almost perfectly symmetrical layout to maximize power delivery to the wheels, and to create balance and stability that can heighten your enjoyment of every experience you have behind the wheel.

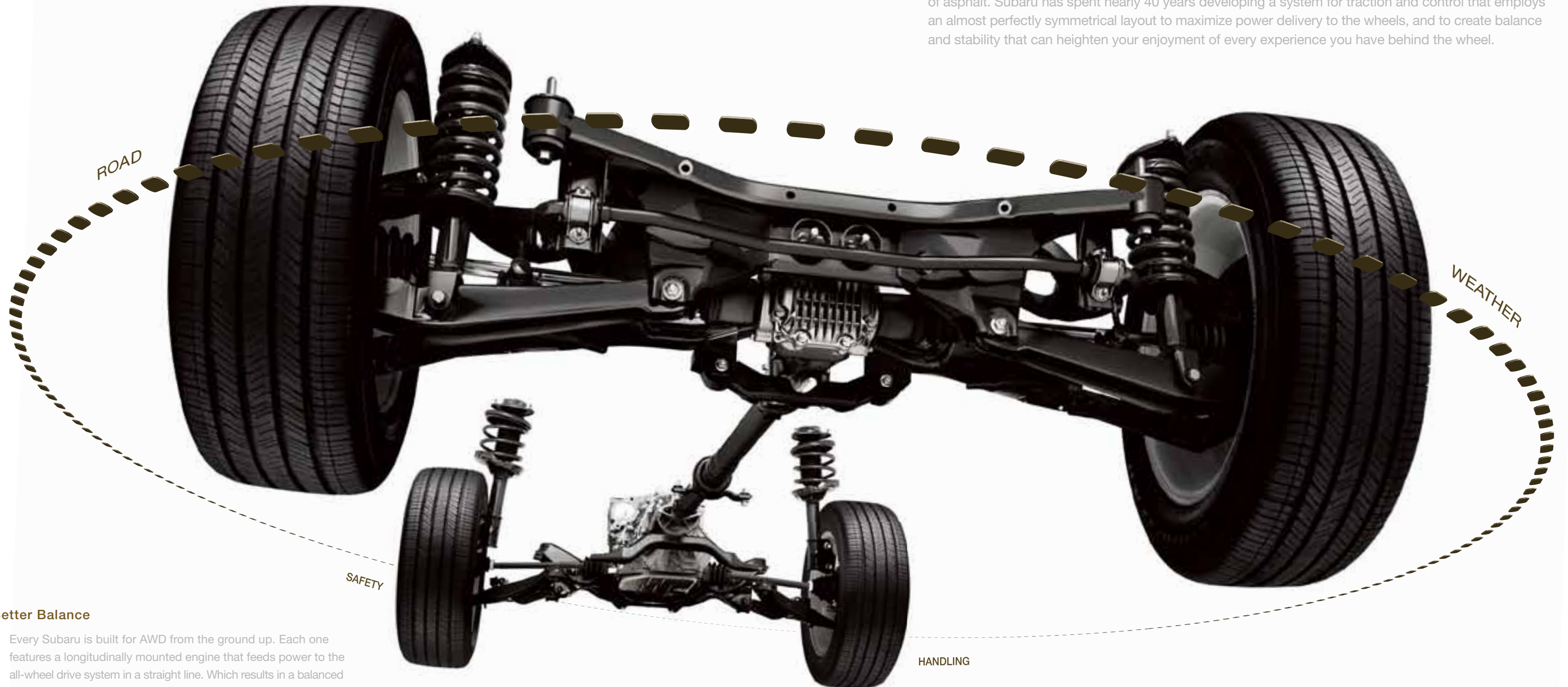

Better Balance

Every Subaru is built for AWD from the ground up. Each one features a longitudinally mounted engine that feeds power to the all-wheel drive system in a straight line. Which results in a balanced drivetrain with almost total side-to-side symmetry that is free of the extra components some other systems need to route power. This symmetry and balance means stability that helps make driving your Subaru safer and agility that makes it more fun.

Quicker Response

There are only four small patches of rubber that keep you in control of your vehicle. The more your tires are engaged, the more control you have. Subaru Symmetrical AWD keeps power routed to all four tires all the time, so it doesn't have to react to slippage that has already occurred. Rather, it keeps your tires as fully engaged with the road as possible.

Efficient Design

Because some systems lack the simplicity of Subaru Symmetrical AWD, they not only sacrifice efficiency, but also can incur more wear and tear. Subaru routes power directly from the engine to all four wheels to keep components—and frictional power losses—to a minimum. All while maximizing the seamless feeling of traction whenever you need it.



Learn more about the benefits of Subaru AWD.
subaru.com/awd



Horizontally Opposed Design

The pistons move in 180-degree opposition to each other on a horizontal plane, so each naturally cancels out the vibration of the piston opposite it.

Durable Construction

The engine's flat design is inherently rigid, and reduces the amount of vibration that "V" or inline engines—with more upright pistons—are subjected to during operation.

Lower Center of Gravity

The flatter profile and perfectly symmetrical design of the engine block, and the fact that it sits lower in the chassis, make the overall vehicle more stably balanced and resistant to side-to-side motion than other designs.

Smoother Operation

Step on the accelerator and the revs come on smooth. While there's plenty of power when you need it, it never compromises your comfort or control.

Increased Durability

An engine subjected to less vibration lasts longer. It's no wonder 94% of Subaru vehicles built in the last 10 years are still on the road today.¹

¹ Based on R. L. Polk & Co. registration data in the U.S. 1998 to 2008.

Greater Agility

The vehicle responds more quickly to changes in direction, which gives a feeling of tightness in turns. And it's less likely to become unstable during maneuvers, giving you an increased feeling of being in control at all times.

An engine that runs
on good ideas.

Subaru Boxer Engine

We think about engines a little differently. We believe it should deliver both power and control. That way, it takes you and your stuff where you want to go, while taking your confidence to new heights. That's why every Subaru is powered by the SUBARU BOXER® engine. Its horizontally opposed design and symmetrical layout provide powerful, yet smooth acceleration, but also give drivers balance and stability that set it apart from engines with a "V" or inline configuration. It's an insightful difference that has the power to make driving more engaging.

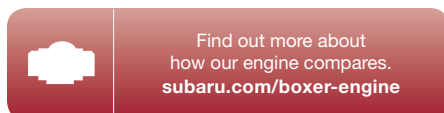



Miles from anywhere.
Right where we love to be.



Refined space.
Abundant rewards.

Tribeca 3.6R Limited with Desert Beige leather and optional Navigation and Rear Seat Entertainment Package.

Well-appointed Interior

The stylish and spacious Tribeca creates an ideal environment for everyone to enjoy and admire. With ambient interior lighting, and available leather-trimmed upholstery, your passengers will appreciate the sophisticated design and relaxing atmosphere. They'll also appreciate rewarding standard features like heated front seats, and dual-zone automatic climate control, which allows you to set two distinct temperatures for yourself and your front passenger, while automatically adjusting the air conditioning to maintain them. A separate rear cabin air conditioner, with a fan control accessible to the 2nd-row passengers, helps keep those in back comfortable, while the available rear-seat DVD entertainment system helps keep them delighted as the miles roll by.

Audio System

With the right soundtrack, every drive can inspire. The Tribeca is now available with the stunning sounds of a harman/kardon® premium audio system. It features 10 speakers placed around the cabin for optimum clarity and impact, each built with premium materials—including neodymium magnets—for harmonic richness. Powering the system is a 385-watt amplifier built and custom-tuned by the audio wizards at harman/kardon. Choose from a variety of audio sources—including an available 6-disc CD changer, an accessory iPod® interface,¹ and a versatile auxiliary jack, which comes standard.

¹ Not available with harman/kardon audio system, available on 3.6R Premium only.



Space to spare. Loaded with potential.

Spacious.



Versatile.



7-passenger seating



50/50-split 3rd row



40/20/40-split 2nd row

Convenient.



74.4 cu. ft. Cargo Space

Many SUVs offer a spacious interior. But the Tribeca fills that space with innovations and designs that are simply smart. Every square inch of the elegant interior is maximized with distinctive features thoughtfully placed and ingenious configurations that mean just about everyone and everything fits. The flexible design lets you conveniently fold all the seats down, creating a cargo area with 74.4 cubic feet of space. With this much space, you won't ever have to leave anyone or anything behind.

Standard 3rd-row Seating

The split-folding 3rd-row seating is now standard on every Tribeca making it more family-friendly than ever. Every Tribeca now has a place for up to seven passengers. What's more, the thoughtful design of the 3rd row allows you to neatly fold down one or both of the seats for easy access to the 37.6 cubic feet of cargo space. And because you can access the 3rd row from both sides of the vehicle, getting to it is always easy.

10 Cup Holders

There's no need to cry over spilled anything with ten cup holders to choose from. Every seat has one within reach. There's two in the center console, one in every door, two in the 2nd-row armrest. And even those in the back aren't left out with two on each side of the 3rd row. You'll also find a variety of conveniently placed storage compartments throughout the interior—helping you carry what you need while cutting down on clutter.

Flexible 2nd Row

Your needs and the needs of those you take with you have a way of changing all the time. The Tribeca is ready to adapt to your life with features like the 40/20/40-split 2nd row. Its seatback splits three ways, so you can seat three across, or fold down one or two of the seatbacks to carry longer items in the cargo area. And to help accommodate varying passenger needs—from infants who need to be within easy reach, to adults who want all the legroom possible—the 2nd row slides almost eight inches forward and backward, and also reclines for comfort.

Touch-screen Navigation

| harman/kardon® Audio

| Hands-free Calling



Elevates every journey.

Interior Features

The Tribeca has a wealth of available features designed to give you the comfort and control to make every drive more rewarding. It's easy to find the perfect driving position with the 8-way adjustable power driver's seat. And steering wheel-mounted controls keep key vehicle settings within easy reach. You'll quickly find your destination with the available touch-screen navigation system, which will also provide you with points of interest along the way. For even greater convenience, BlueConnect® hands-free Bluetooth® calling is available on every Tribeca. This feature allows you to pair a Bluetooth-enabled phone, and make your calls with voice commands. It can even store a phonebook of numbers to make calling easier.



Discover in-depth the Subaru safety advantage. subaru.com/safety

Protected from every angle.



Government Crash Test Rating¹
—National Highway Traffic Safety Administration

2009 IIHS Top Safety Pick²
—Insurance Institute for Highway Safety



Subaru Active and Passive Safety

When it comes to feeling confident, nothing is more important than feeling safe. That's why Subaru places safety as one of our highest priorities, and why we think about safety in 360 degrees. First, we engineer our vehicles with exceptional control and advanced accident-avoidance technologies to help keep accidents from happening in the first place. Then, we build every Subaru with protection technologies that help keep danger out, while helping to keep those inside safe. The end result is a car that—in a worst-case scenario—is one of your best possible bets.



Stopping Power

Powerful and reliable vented disc brakes are teamed with advanced technology to help you stop short of danger. Antilock brakes help make sure you don't lose traction, and the advanced Brake Assist system helps ensure maximum pressure is applied to the brakes as quickly as possible in an emergency situation.

Increased Awareness

Before you can avoid danger, you have to see it coming. Not only is the Tribeca designed for excellent visibility on all sides, it's also available with a back-up camera. The optional rear-vision camera, with available 3.5-inch display located conveniently in the rearview mirror, gives you a clear view behind you. Upgrade to the navigation system, and you'll have a 7-inch, in-dash display.



Exceptional Control

Safety begins with avoidance. The traction and balance of Subaru Symmetrical All-Wheel Drive and the stability of the SUBARU BOXER® engine provide you with the outstanding control you need to react to hazards. Every Tribeca also comes standard with VDC electronic stability control, which can detect a loss of control and intervene to help keep you on your intended path.



All-around Protection

Our Ring-shaped Reinforcement Frame is exceptionally strong for maximum resistance to impact energy, while its unique configuration helps divert that energy away from occupants. To further help prevent injury, an array of sensors, including a rollover sensor, can detect an impending crash and deploy front, front-side and side-curtain airbags³—working to surround and cushion outboard occupants.

¹ Government star ratings are part of the National Highway Traffic Safety Administration's (NHTSA's) New Car Assessment Program. Visit safercar.gov for more information.

² Ratings based on Insurance Institute for Highway Safety's (IIHS's) 40-mile-per-hour frontal crash test, 31-mile-per-hour side-impact test, and 20-mile-per-hour rear-impact test. For more information, contact IIHS or visit their website at www.iihs.org.

³ Always wear seatbelts. Children should be properly restrained in the rear seat.

This is how we show our love.

Building Cars That Last

Life is too important to slow down with a car you can't rely on. That's why we build each of our vehicles with the highest standards of manufacturing, and with designs that are inherently tough, and engineering that can keep you going, and keep you out there. This commitment is why 94% of all the vehicles we've built in the last 10 years are still on the road today.¹ And why a Subaru can keep its value, and stay out of a landfill longer.

¹ Based on R. L. Polk & Co. registration data in the U.S. 1998 to 2008.



Supporting Partners That Care

Subaru has spent decades building relationships with dozens of organizations that believe in building a cleaner, greener, healthier and more hopeful world as much as we do. That's why you'll see us offering our support at events like Dining Out for Life, or promoting responsible recreation with Leave No Trace. Our Share the Love sales event harnessed the generosity of Subaru owners to raise nearly five million dollars for the following deserving causes: ASPCA, Habitat for Humanity, National Wildlife Federation, Meals on Wheels and Boys & Girls Clubs.



Protecting Your Investment

Once you're part of our family, we'll be there for you. Every Subaru comes with 24-hour roadside assistance for 3 years or 36,000 miles. If you have trouble on the road, a tow to the nearest Subaru dealership and other services are just a phone call away. And to protect you over the long haul, we offer Subaru Added Security[®]—extended service agreements and maintenance plans that will help protect your car for up to 7 years or 100,000 miles. They're the only mechanical and maintenance plans backed by Subaru of America, Inc., and because we've been backing them for more than 25 years, they're agreements you can trust. Your dealer has full coverage details.



Ensuring You're Fully Covered

We know you love your Subaru, but sometimes accidents happen. Subaru Equity Shield™ GAP could help you avoid further sorrow by paying all or most of a possible difference between what your insurance company covers for your Subaru that was totaled, or stolen and not recovered, and what you still owe in payments. It will even cover your deductible for up to \$1,000. Also, being part of the Subaru family may save you money on some types of insurance, such as auto and homeowners. Subaru owners may be eligible for exclusive rates through Subaru Advantage Insurance by Liberty Mutual. Find out more at subaru.com.

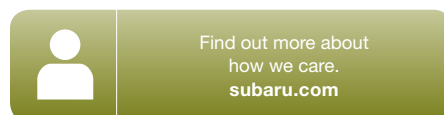

You'll want to bring more
and drive more.



Tribeca 3.6R Limited in Ruby Red Pearl with optional Power Moonroof Package.

Dynamic Handling

With surefooted capability and excellent cargo and towing capacity, the Tribeca is no lightweight. But the way it handles is anything but heavy or sluggish. It features a 4-wheel independent suspension tuned for an ideal balance of sharp responsiveness and smooth, comfortable compliance. With a double-wishbone rear design, this versatile suspension helps the Tribeca react effortlessly to changing road conditions while responding quickly to your input. But the true core of its inspiring control and surprising agility is Subaru Symmetrical All-Wheel Drive. Its exceptionally balanced design helps the Tribeca maneuver more predictably, while at all times grabbing hold of as much of the road as possible.

6-cylinder Subaru Boxer Engine

Every Tribeca is powered by the 3.6-liter 6-cylinder SUBARU BOXER® engine, the largest engine Subaru offers. With 256 horsepower, it delivers more than enough power to inspire confidence in virtually any driving condition. And with a unique horizontally opposed design, that power is delivered with exceptional smoothness and stability. The Tribeca also comes standard with the smooth-shifting 5-speed automatic transmission featuring SPORTSHIFT technology. This means you can take manual control over how the Tribeca shifts for greater involvement and access to power when you want it.





Never been lost.
Still love to wander.

Log on and take off.

Subaru Gear
subarugear.com

Drive Magazine
subaru.com/drive

Our Partners
subaru.com/partners

What makes a Tribeca, a Tribeca.



Making the final decision to purchase a vehicle can be complex. That's why you'll find everything you'll need to know about being a Tribeca owner at subaru.com. Not only will you find images of the Tribeca and detailed information about it, but you'll also be able to check out special offers, ratings, reviews, and news about Subaru. We've also provided a wealth of interactive tools to help you decide if a Subaru is right for you.

subaru.com/vehicles/tribeca

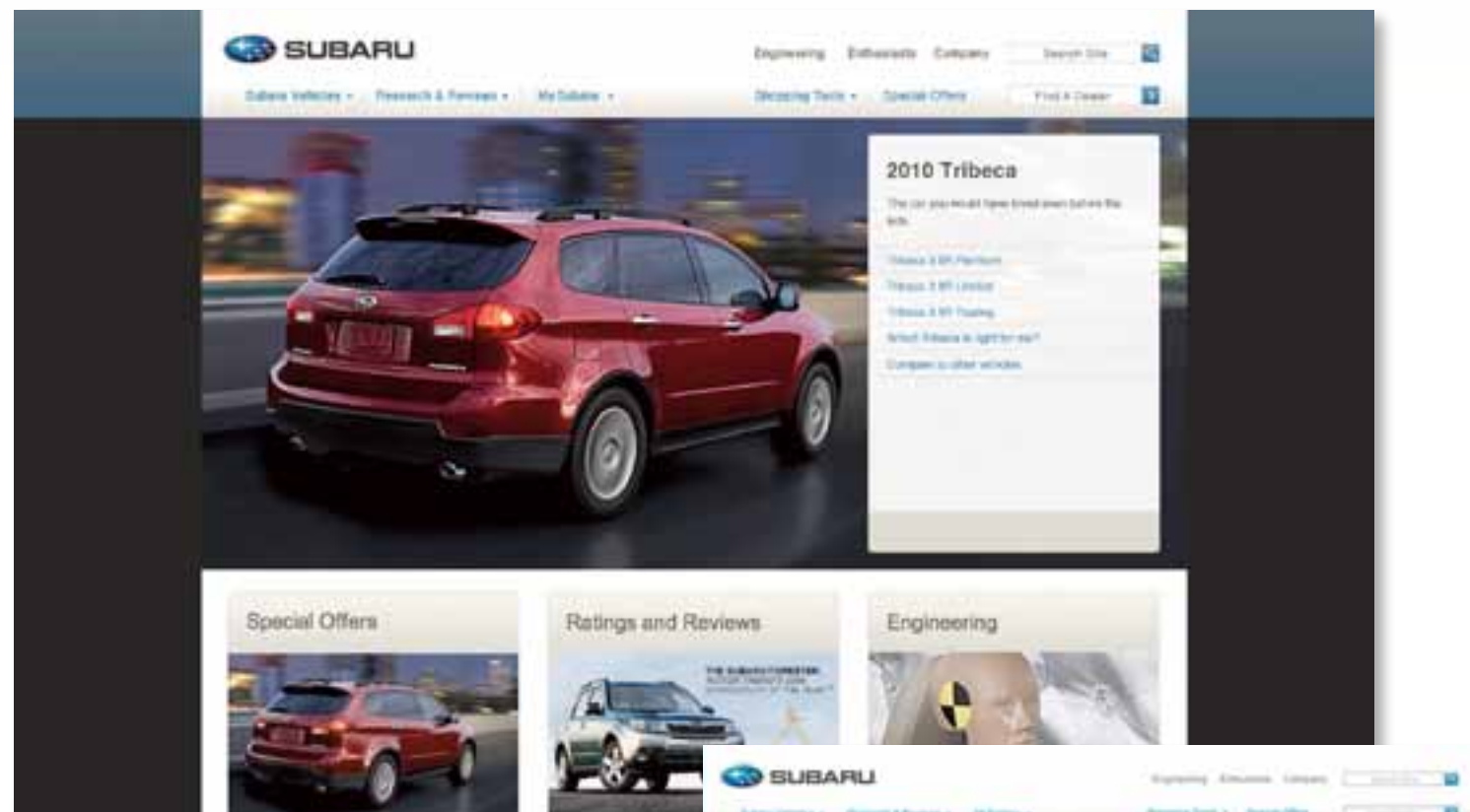

Discover the Subaru difference.

What makes a car special is not always found on the surface. Go here to delve beneath the skin of the Tribeca to find out what really makes it drive and complement your life so well.

subaru.com/engineering



Does it measure up?

Sometimes you need to see your choices side-by-side to really make a decision. Get in-depth information on the Tribeca and how it compares to the competition in just about every category.

subaru.com/tools/compare-vehicles



Configure your own.

With a wide variety of trim levels, colors and options to choose from, there is a Tribeca for you. Use this tool, and within a few minutes you'll know exactly which Tribeca that is.

subaru.com/vehicles/build

Need an expert opinion?

The Tribeca has been tested, analyzed and put through its paces by some of the toughest critics in the automotive field. Find out what they thought about the value the Tribeca has to offer.

subaru.com/ratings-and-reviews



There's a Tribeca for you.



Tribeca Trim Levels

3.6R Premium Room for seven is just the start. Get the capability, cargo capacity, and full complement of safety features that make a Tribeca such a pleasure to own. You'll also enjoy a rewarding list of standard features that include 18" alloy wheels, a 7-inch in-dash multifunction screen, automatic climate control, heated front seats, and a reclining, sliding and tri-split folding 2nd row. In the cargo area, an underfloor tray helps you stow more things more safely.

3.6R Limited It's a more luxurious way to enjoy Tribeca versatility and performance, with more features and refinement. Leather-trimmed upholstery and heated front seats will enhance your comfort. BlueConnect® hands-free Bluetooth® calling comes standard. A 10-speaker, 385-watt harman/kardon® premium audio system will take all your music to a new level. Standard XM® Satellite Radio and an available touch-screen navigation system lead a long list of advanced technology features.

3.6R Touring Rewarding features abound with Tribeca 3.6R Touring, while a wide list of styling features set it apart. You'll get the comfort of a power moonroof and leather-trimmed upholstery, along with the powerful sounds of the harman/kardon premium audio system. On the outside, HID headlights, silver color roof rails, upgraded 18" alloy wheels, and a stylish monochromatic paint scheme enhance its visual appeal. You also enjoy standard BlueConnect hands-free Bluetooth calling and a back-up camera with a 3.5-inch display standard.

Paint

Exterior



Satin White Pearl

Steel Silver Metallic

Sky Blue Metallic

Azurite Blue Pearl



Ruby Red Pearl

Deep Bronze Metallic

Graphite Gray Metallic

Crystal Black Silica

Upholstery



Slate Gray Cloth (SGC)

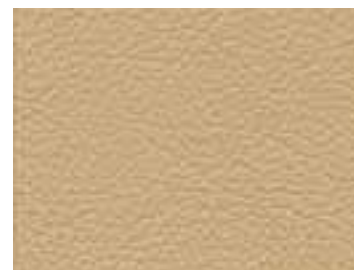

Desert Beige Leather (DBL)



Slate Gray Leather (SGL)

Tribeca Color Combinations

PAINT	3.6R Premium	3.6R Limited	3.6R Touring
Satin White Pearl	-	DBL	-
Steel Silver Metallic	SGC	SGL	SGL
Sky Blue Metallic	SGC	SGL	-
Azurite Blue Pearl	-	DBL	DBL
Ruby Red Pearl	-	DBL	DBL
Deep Bronze Metallic	-	DBL	-
Graphite Gray Metallic	SGC	SGL	SGL
Crystal Black Silica	-	DBL	DBL

Tribeca® Specifications

ENGINE AND DRIVETRAIN	3.6R Premium, 3.6R Limited and 3.6R Touring		
Engine	3.6-liter DOHC aluminum-alloy 24-valve 6-cylinder horizontally opposed SUBARU BOXER® engine with Dual Active Valve Control System (DAVCS). Low-friction pistons. Iridium spark plugs.		
Power	256 hp @ 6,000 rpm		
Torque	247 lb-ft @ 4,400 rpm		
Transmission	Standard 5-speed adaptive electronic direct-control automatic with SPORTSHIFT® manual control		
CA Emissions	Certified Low Emission Vehicle (LEV2 LDT2)		
FUEL			
Fuel economy (city/highway)	16/21 mpg ¹		
Fuel requirement	Unleaded gasoline (87 octane)		
SYMMETRICAL ALL-WHEEL DRIVE			
Variable Torque Distribution (VTD)	VTD All-Wheel Drive utilizes an electronically controlled variable transfer clutch in conjunction with a planetary-type center differential. Torque distribution is normally configured at a performance-oriented rear-wheel-biased 45/55-split front-to-rear. Utilizing Vehicle Dynamics Control (VDC) sensors, VTD All-Wheel Drive evaluates road conditions by continually estimating surface friction and adjusting torque distribution accordingly front-to-rear for optimum traction.		
STABILITY AND TRACTION			
Vehicle Dynamics Control (VDC)	Standard VDC electronic stability control utilizes sensors which constantly monitor wheel speeds, steering angle, brake pressure, vehicle yaw rate and lateral g-forces. If VDC detects a difference between the driver's intended path and the one the vehicle is actually taking, VDC applies braking power and/or reduces engine torque to help correct vehicle path.		
Traction Control System (TCS)	VDC also incorporates an all-wheel, all-speed traction control system which senses a loss of traction and applies braking force to the slipping wheel or wheels as necessary to maintain vehicle motion.		
CHASSIS			
Steering	Engine-speed-sensing power-assisted rack-and-pinion. Turning circle: 37.4 feet.		
Suspension	4-wheel independent suspension. Front: Strut-type with lower L-arm. Stabilizer bar. Rear: Double wishbone. Stabilizer bar.		
Brakes	4-wheel disc, ventilated front. 4-channel, 4-sensor ABS with Electronic Brake-force Distribution (EBD).		
Brake Assist	When emergency braking is detected by how quickly the brake pedal is pressed, maximum brake pressure is immediately applied.		
Brake discs	Front: 12.3 inches/ Rear: 12.4 inches		
WHEELS AND TIRES			
Wheels	3.6R Premium and 3.6R Limited: 18 x 8.0-inch 5-dual-spoke aluminum alloy. 3.6R Touring: 18 x 8.0-inch 7-spoke aluminum alloy.		
Tires	255/55 R18 104H M+S all-season		
EXTERIOR DIMENSIONS			
Length	191.5 inches		
Width (including side mirrors)	88.8 inches		
Height	66.4 inches (67.7 inches with roof rails)		
Wheelbase	108.2 inches		
Track (front/rear)	62.2 inches/62.1 inches		
Base curb weight	3.6R Premium: 4,120 lbs	3.6R Limited: 4,214 lbs	3.6R Touring: 4,256 lbs
INTERIOR DIMENSIONS			
Headroom (front/rear)	40.3 inches/38.2 inches (38.9 inches/38.2 inches with moonroof)		
Legroom (front/2nd row/3rd row)	42.3 inches/34.3 inches/30.9 inches		
Shoulder room (front/2nd row/3rd row)	58.1 inches/57.5 inches/51.3 inches		
Passenger volume	133.5 cubic feet		
Cargo volume	37.6 cubic feet with 2nd-row seats raised/8.3 cubic feet with 2nd- and 3rd-row seats raised		
Maximum cargo volume	74.4 cubic feet with 2nd- and 3rd-row seats lowered		

Tribeca® Equipment

EXTERIOR	3.6R Premium	3.6R Limited	3.6R Touring
Projector low-beam and multireflector high-beam headlights	●	●	–
High intensity discharge (HID) low-beam and multireflector halogen high-beam headlights	–	–	●
Foglights	●	●	●
Front bumper underguard ²	–	–	●
Chrome-finished door handles	●	●	●
Body-color side sills and front and rear lower bumper area	–	–	●
Body-color power mirrors with integrated turn signals	●	●	●
Heated side mirrors and windshield wiper de-icer	●	●	●
2-speed windshield wipers with variable intermittent mode and mist feature	●	●	●
Bright-finish dual exhaust outlets	●	●	●
Power tilt/sliding-glass moonroof ³	–	○	●
Privacy glass for rear doors, rear quarters and rear gate	●	●	●
Raised roof rails ³ , black-finish (3.6R Limited) or silver-finish (3.6R Touring). 150 lbs capacity.	–	○	●

SEATING AND TRIM

8-way power driver's seat and 4-way power front-passenger's seat, both with manually adjustable lumbar support	●	●	●
3-stage heated front seats	●	●	●
2-position driver's seat memory	–	●	●
60/40-split sliding and reclining 2nd-row seats with 7.8-inch fore/aft travel and driver/passenger-side tip-forward/slide function for 3rd-row entry/exit	●	●	●
40/20/40-split flat-folding 2nd-row seatbacks. 50/50-split flat-folding 3rd-row seatbacks.	●	●	●
Rear-center armrest	●	●	●
Leather-wrapped shifter handle	●	●	●
Leather-trimmed upholstery	–	●	●
Premium cloth upholstery	●	–	–
Silver metallic trim on dashboard, doors and center console	●	●	●

CONVENIENCE FEATURES

Auto-dimming rearview mirror with integrated back-up camera in 3.5-inch display ³	–	○	●
Power front and rear windows with driver's auto-down	●	●	●
Electronic cruise control	●	●	●
Integrated key fob with door lock/unlock, rear gate unlock and panic function	●	●	●
Leather-wrapped 3-spoke steering wheel with audio system buttons	●	●	●
Center console with armrest, enclosed storage compartment and rear storage drawer	●	●	●
10 cup holders	●	●	●
Overhead console with dual maplights and either sunglasses storage (3.6R Premium) or Bluetooth® wireless phone module (3.6R Limited and 3.6R Touring)	●	●	●
HomeLink® remote transmitter with 3 memory settings	–	●	●
Courtesy lighting in overhead console, doors, rear-cabin area, cargo area and tailgate	●	●	●
Automatic ambient lighting of center console area	–	●	●
Illuminated front- and 2nd-row footwells (when entering or exiting vehicle)	●	●	●
Dual 12-volt power outlets in center console storage compartment. Dual 12-volt power outlets in cargo area.	●	●	●
Cargo-area underfloor storage	●	●	●
4 cargo-area tiedown hooks and dual cargo-area grocery hooks	●	●	●

AUDIO AND COMMUNICATION SYSTEMS

100-watt 6-speaker audio system with single-disc in-dash CD player and MP3 capability	●	–	–
385-watt 10-speaker harman/kardon® premium audio system with amplifier, subwoofer, MP3/WMA playback capability, Bluetooth wireless phone capability and XM® Satellite Radio ⁴	–	●	●
Auxiliary audio jack for portable media players	●	●	●
XM® or SIRIUS® Satellite Radio capability ⁵	●	–	–

INSTRUMENTATION

Analog speedometer and tachometer with illuminated red needles on black faces and white indicators	●	●	●
Digital coolant temperature and fuel gauges. Digital odometer and automatic transmission shift-position indicator.	●	●	●
Electroluminescent lighting	●	●	●
Multifunction screen displaying clock, audio system, ambient temperature and fuel economy information	●	●	●

CLIMATE CONTROL	3.6R Premium	3.6R Limited	3.6R Touring
Dual-zone automatic climate control system with air filtration and controls for temperature, 6-speed fan, airflow direction, automatic mode and CFC-free air conditioning	●	●	●
Rear cabin air conditioner with 4-speed fan	●	●	●

SECURITY

Keyless entry system with tailgate unlock and answer-back electronic chirp	●	●	●
Antitheft security system with engine immobilizer and answer-back electronic chirp	●	●	●

SAFETY

ACTIVE			
Subaru Symmetrical All-Wheel Drive	●	●	●
SUBARU BOXER® engine	●	●	●
4-wheel Antilock Braking System (ABS) with Electronic Brake-force Distribution (EBD)	●	●	●
Vehicle Dynamics Control (VDC)	●	●	●
Traction Control System (TCS)	●	●	●
Brake Assist	●	●	●
Tire Pressure Monitoring System (TPMS)	●	●	●
Daytime Running Lights (DRL)	●	●	●
PASSIVE			
Dual-stage deployment driver's and front-passenger's front airbags (SRS) ⁶	●	●	●
Subaru advanced frontal airbag system ⁶	●	●	●
Side-curtain airbags protecting front and outboard 2nd-row occupants (SRS) ⁶	●	●	●
Front side-impact airbags (SRS) ⁶	●	●	●
Height-adjustable active front-seat head restraints	●	●	●
Three individual height-adjustable 2nd-row headrests. Two individual height-adjustable 3rd-row headrests.	●	●	●
3-point height-adjustable outboard 2nd-row and fixed 2nd-row center seatbelts. 3-point fixed 3rd-row rear seatbelts.	●	●	●
Emergency Locking Retractors at all seating positions	●	●	●
Rear child-safety door locks. LATCH system: Lower Anchors and Tethers for Children.	●	●	●
Energy-absorbing collapsible steering column. Safety brake pedal system.	●	●	●
Ring-shaped Reinforcement Frame body structure	●	●	●
Rollover sensor (SRS) ⁶	●	●	●
Rear-vision camera	–	○	●

OPTIONAL EQUIPMENT

Power Moonroof Package: Power tilt/sliding-glass moonroof, auto-dimming rearview mirror with integrated back-up camera in 3.5-inch display, Raised roof rails (150 lbs capacity)	–	○	●
Navigation Package: Touch-screen GPS navigation system with multifunction screen displaying rear-vision camera, audio system information, trip computer functions, outside temperature, maintenance intervals, controls for various vehicle settings, calendar, calculator and memo-taking function. Auto-dimming rearview mirror with compass.	–	○	○
Navigation and Rear Seat Entertainment Package: Touch-screen GPS navigation system (see description above). Rear-seat DVD entertainment system (RSES) with 9-inch widescreen format, 2 wireless headsets, wireless remote, and auxiliary inputs for game console, video camera or other multimedia device. Video input from RSES may also be displayed on in-dash screen (with vehicle in Park). Auto-dimming rearview mirror with compass.	–	○	○

WARRANTIES

New Car Limited Warranty: 3 years or 36,000 miles, whichever comes first. **Powertrain Limited Warranty:** 5 years or 60,000 miles, whichever comes first. **Wear Item Limited Warranty:** 3 years or 36,000 miles, whichever comes first. Repairs to the following items will also be covered under Wear Item Limited Warranty: • Brake Pads • Wiper Blades • Clutch Linings • Transmitter Batteries **Rust Perforation Limited Warranty:** 5 years, unlimited mileage.

● Standard ○ Optional – Not available

¹ 2010 EPA fuel economy estimates. Actual mileage may vary. ² Available as an accessory on 3.6R Premium and 3.6R Limited. See your dealer. ³ Available on 3.6R Limited as part of option package. See equipment listing above. ⁴ Activation and monthly subscription sold separately. See your dealer. ⁵ Satellite radio hardware and required monthly subscription sold separately. See your dealer. ⁶ The Supplemental Restraint System (SRS) (airbags) affords the driver and front passenger additional protection in moderate to severe frontal and side-impact collisions, and outboard 2nd-row passengers additional protection in moderate to severe side-impact collisions. This system provides supplemental protection only, and seatbelts must be worn in order to avoid injuries to out-of-position occupants upon bag deployment and to provide the best combined protection in a serious accident. Children should always be properly restrained in the rear seat.

Some images shown are for illustration purposes only. Specifications in this brochure are based on the latest product information available at the time of publication. For the most up-to-date product information, log on to subaru.com. Some equipment shown in photography in this brochure is optional at extra cost. Specific options may be available only in combination with other options. Specific combinations of equipment or features may vary from time to time and by geographic area. Certain accessories and equipment may not be available at the time of publication. Subaru of America, Inc., reserves the right to change or discontinue at any time, without notice, prices, colors, materials, equipment, accessories, specifications, models and packages without incurring any obligation to make the same or similar changes on vehicles previously sold. Colors shown may vary due to reproduction and printing processes.

This brochure was prepared by Subaru of America, Inc. A warranty from Subaru of America, Inc., is available only on cars sold to the first retail purchaser through an authorized Subaru dealer in the continental U.S. or Alaska. Subaru, SUBARU BOXER, Subaru Added Security and Tribeca are registered trademarks. SIRIUS and XM Radio are registered trademarks of SIRIUS XM Radio Inc. iPod is a registered trademark of Apple Inc. SPORTSHIFT is a registered trademark of Prodrive Ltd. HomeLink is a registered trademark of Prince Corporation, a wholly-owned subsidiary of Johnson Controls. Bluetooth is a registered trademark of Bluetooth SIG, Inc. BlueConnect is a registered trademark of Johnson Controls, Inc. For more information, contact your Subaru dealer or log on to subaru.com.



All-weather Mats

Custom-fitted, heavy-gauge protective mats. They help protect vehicle carpet from sand, dirt and moisture.



Moonroof Air Deflector

This air deflector helps reduce wind noise and cut sun glare.



Remote Engine Starter

Conveniently allows vehicle to start by remote control (up to 400 feet away depending on obstructions), so that the vehicle's interior temperature is more comfortable upon entry.



Front Bumper Underguard

Adding a touch of style to a rugged profile, the front bumper underguard protects the lower bumper area from brush and debris.



Trailer Hitch

When your toys are too big to fit inside, the Trailer Hitch may be what you need. Rated at 350 lbs. tongue weight and 2,000 lbs. towing capacity (3,500 lbs. with addition of accessory Transmission Oil Cooler).

Hitch ball not included. Trailer brakes may be needed.



Puddle Lights

LED lights mounted in the rocker panel trim turn on when the vehicle doors are unlocked using the keyless entry and illuminate the ground to aid entering and exiting the vehicle.



Cargo Net – Rear

Neatly holds cargo and prevents it from sliding about while the vehicle is in motion.



18-inch Chrome-finished Alloy Wheel

Ride even more stylishly with these 18-inch chrome-finished alloy wheels.



Hood Protector

The hood protector is made from a durable acrylic material that helps shield the hood from bugs and stone chips.



Kayak Carrier

Cradles and securely transports most kayak hull shapes. Includes tie-down straps with padded buckles.

Required mounting clamps sold separately. Shown with accessory Round Cross Bars, also sold separately.



Dog Guard/Compartment Separator

Provides a divider between your cargo or pet and the passenger area of the Tribeca.



Rear Bumper Cover

Helps protect upper surface of rear bumper from scratches and dings.



The earth isn't disposable. Neither is a Subaru.

The Tribeca may be uniquely designed for getting out there, but at Subaru, we put just as much emphasis on not leaving it out there. First, we build vehicles for maximum **durability**, because more time spent on the road is less time in a landfill. It's why 94% of the vehicles we've built in the last 10 years are still on the road today.¹ We also work diligently to cut waste before the car ever rolls out of the factory. In 2004, Subaru of Indiana Automotive, Inc. (SIA) became the first manufacturing facility in the U.S. to reach **zero landfill** status—nothing from its manufacturing efforts ever goes into a landfill. Subaru facilities in Japan have achieved similar goals in reusing and recycling. And, because clear skies are just as important as clean landscapes, we also work to build cars that use fuel efficiently. Our efforts have made the Subaru lineup of vehicles the most fuel-efficient all-wheel drive lineup in America.²

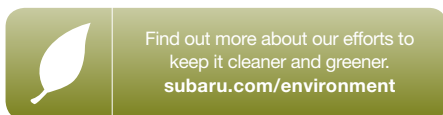

¹ Based on R. L. Polk & Co. registration data in the U.S. 1998 to 2008. ² Based on 2009 model year EPA combined estimated fuel economy for AWD and 4WD. Subaru average EPA city estimate is 18.7 mpg and highway estimate is 25.0 mpg. Actual mileage may vary.



These brochures were printed with vegetable-based inks and produced using a "Green Printing Process" and FSC standards. The Forest Stewardship Council (FSC) is an international organization that brings people together to find solutions which promote responsible stewardship of the world's forests and environments.

By producing these brochures in a green way rather than by traditional methods, we saved 54 trees preserved for the future; 155 lbs water-borne waste not created; 22,869 gallons wastewater flow saved; 2,530 lbs solid waste not generated; 4,982 lbs net greenhouse gases prevented; 38,133,550 BTUs energy not consumed.

